



SPECIAL TEAMS

2007

vs. WINSTON-SALEM STATE



vs. NORFOLK STATE



vs. FLORIDA A&M



vs. HAMPTON





PUNT DEFENSE TEAM

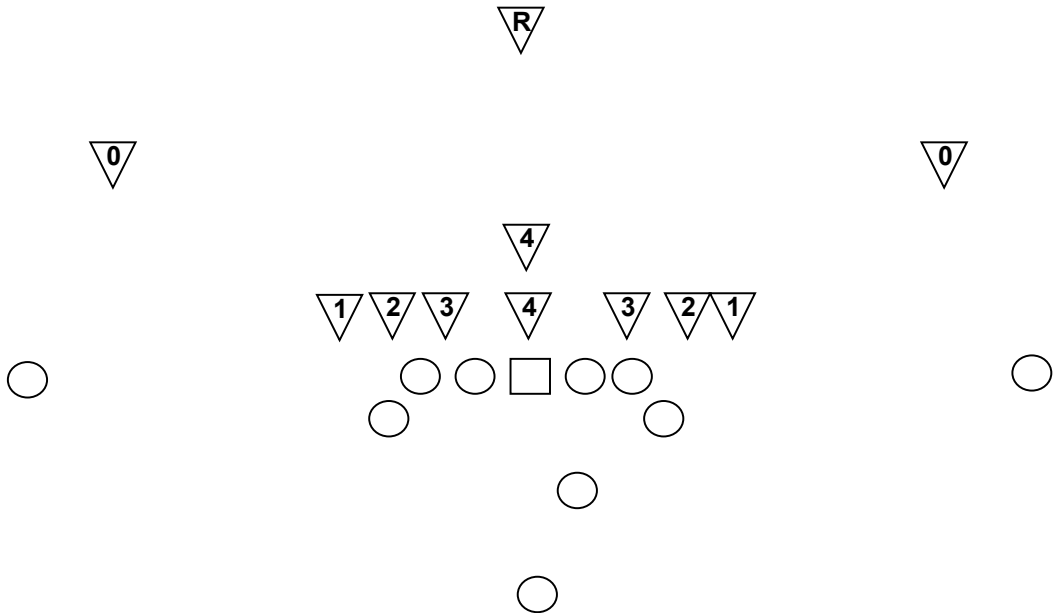

SYSTEM ANALYSIS

The Bulldogs have a 4-4 Stack Punt Defense. They will sneak in the off #4 and overload the LS.

Block 7, Return 10, Safe 3 RETURNS

Block Tech: Hold Up

Weakness: Hold Ups, Cover CB Block Point:

Overall Quality: Very speedy & aggressive Unit.

BLOCKS

NOPE

SHIFTS/MOTION

The Off #4 is moving around

SUMMARY

The Bulldogs will start with Punt Blocks & than when they are not successfull they will switch to set up the Return. They are very aggressive (Off Sides!!) up front! No Scoop & Score Techniques!

ANY BLOCKED PUNTS?

NOPE

How?

When?

KEY OBSERVATIONS

Depth of the Off #4 shows the Play! Overloads always Rush Sides!

REVERSE

NOPE

RETURNERS

#3 Oliver „Tre“ Young, WR, RSO Alignment: Head Up Punter

Acceleration: Great

Speed: Great

Field Ability: Great

Courage: Great

Overall Ability: Outstanding

Returner Who will goes for 6 every

Time! STATS

6-54Y

Ø 9Y

TD 0, Longest 54Y

TOTALS

10-76Y

Ø 7,6Y, TD0



PERSONAL PUNT RETURNER



#3 Oliver "Tre" Young
Wide Receiver
6-0, 180 R-Sophomore
Charleston, SC (Burke High)

Enjoyed a very productive spring and is slated to start this fall at one of the outside receiver slots... Is one of the most talented receivers on the Bulldog squad and is expected to draw a lot of attention around the MEAC... Has "big play" ability and can really stretch the field and make plays... A candidate for postseason honors... **2006:** Competed in all but one of the team's eleven (11) contests... Was one of the top reserves in the receiver corps... Had six catches for 186 yards and two touchdowns... Also had four rushes for 46 yards and a touchdown... **2005:** Was redshirted... **High School:** Lettered in four sports at Burke High - football (4), basketball (4), baseball (3) and track (1)... Earned All-State and All-Region honors in both football and basketball... **Personal:** An electrical engineering technology major... born October 25, 1985... the son of Cynthia and Oliver Young, Jr.

Young's Season Statistics

Season	GP	Rec.	Yds	Avg.	TDs
2006	10	6	186	31.0	2



25 Byron Bush
Wide Receiver
5-10, 187 R-Junior
Aiken, SC (South Aiken High)

Had a solid spring and positioned himself in the top four receiver rotation... A strong showing in the preseason could earn him a starting nod... His knowledge and ability make him a valuable asset to the receiving corps... Expected to play a larger role in 2007 than he did last season... **2006:** Played a reserve role for the Bulldogs in... Appeared in all 11 contests but had just one catch for seven (7) yards... Was also a regular on special teams where he made a significant contribution... **2005:** Saw time in three games both on special teams and at the wide receiver position... had two catches last season for 26 yards... had a season-long 20-yard catch... **2004:** Sat out the season as a redshirt... **High School:** Earned four letters in football at South Aiken High School... also garnered letters each in basketball and track & field... earned numerous honors on the gridiron including All-Region and All-CSRA honors as a senior in 2003... was also an honorable mention on the 2001 All-Area team. **Personal:** An Accounting major... born on December 10, 1985... the son of Loretta and Howard Bush.

Bush's Career Statistics

Season	GP	Rec.	Yds.	Avg/C	TDs	Avg/G
2005	5	2	22	11.0	0	4.4
2006	11	1	7	7.0	0	0.6
Tot	16	3	29	9.6	0	1.8

PUNT RETURN STATS

PUNT RETURNS	No.	Yds	Avg	TD	Long
YOUNG, Oliver	6	54	9.0	0	54
BUSH, Byron	2	5	2.5	0	5
SMITH, Terrance	1	1	1.0	0	1
HENRY, Dominique	1	16	16.0	0	16
Total.....	10	76	7.6	0	54
Opponents.....	11	205	18.6	1	72



PUNT BLOCK (4-4 STACK)

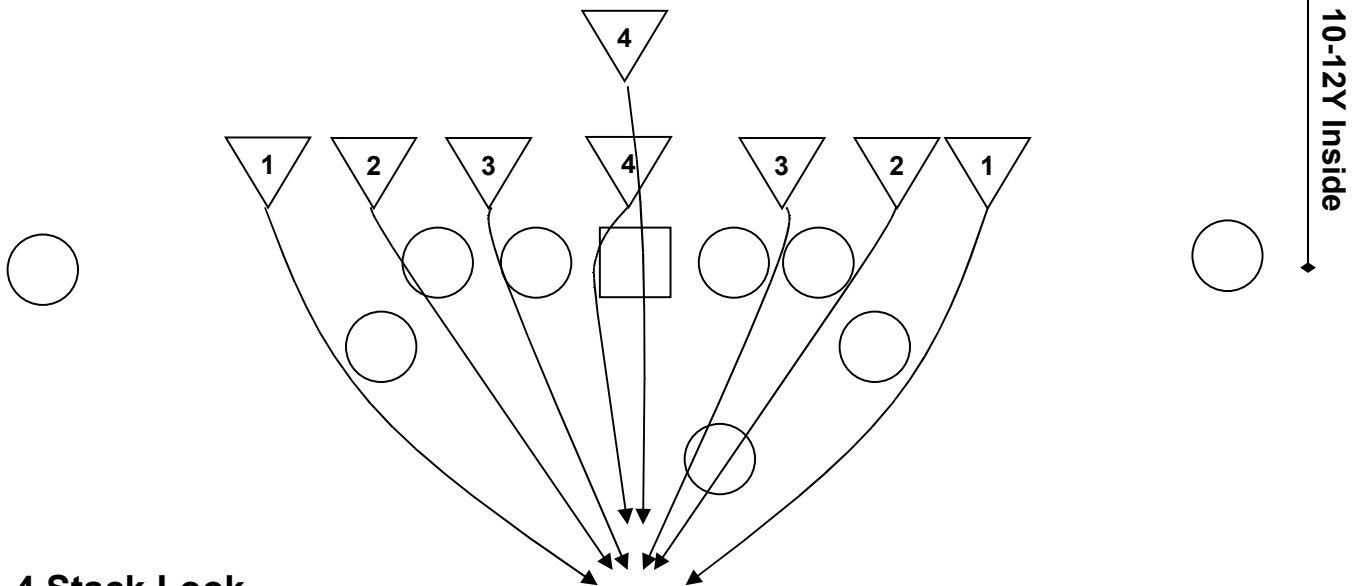
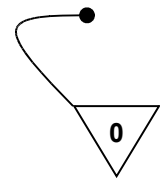
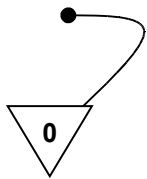

4-4 Stack Look

Right Side:

On #4: Head Up LS > Loop Right A Gap

#3: Outside Shoulder G > B Gap

#2: Outside Shoulder T > C Gap

#1: Outside W > D Gap

Left Side:

Stack #4: Sneak > Left A Gap

#3: Outside Shoulder G > B Gap

#2: Outside Shoulder T > C Gap

#1: Outside W > D Gap





PUNT BLOCK (4-3 OFF)

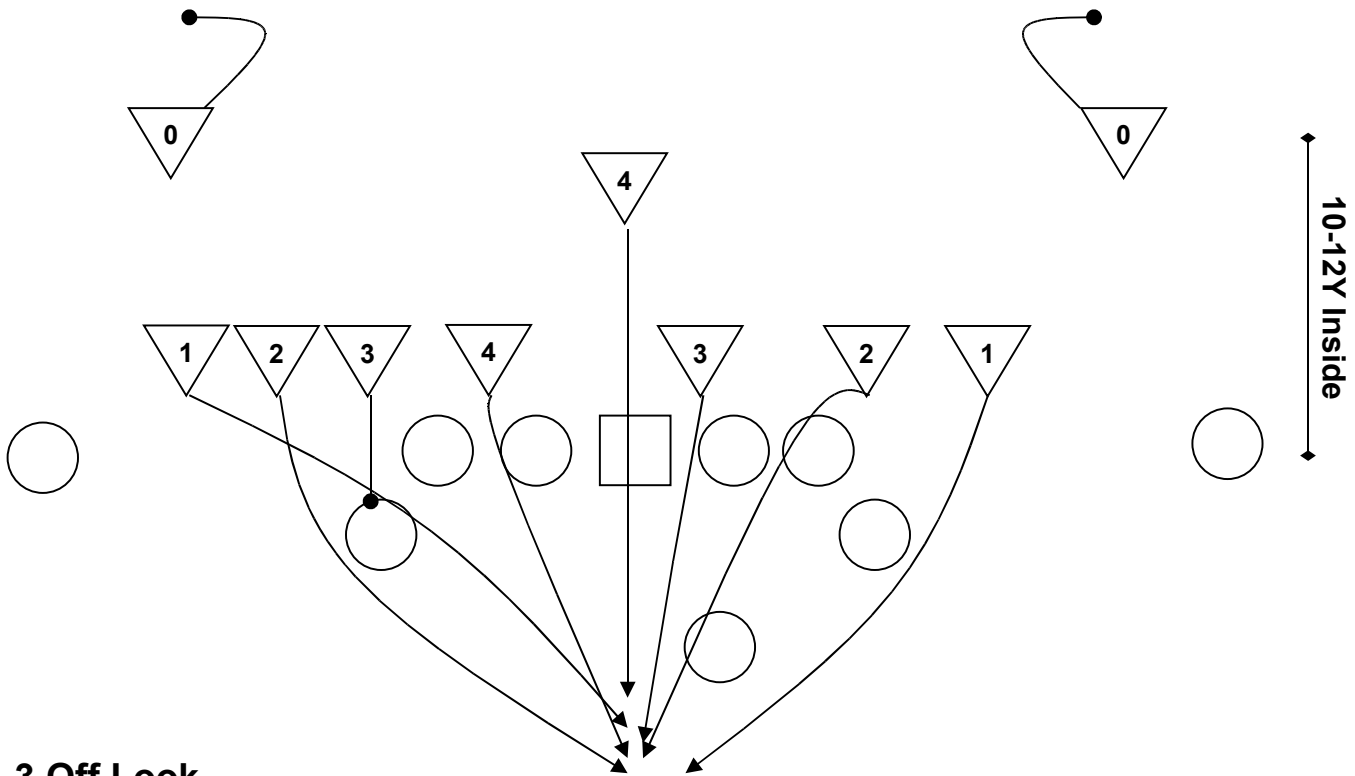

4-3 Off Look

4 Side:

- #4: Outside Shoulder G > B Gap
- #3: Head Up W > Push Back Wing
- #2: Outside > D Gap
- #1: Wide Outside > Crack C Gap

3 Side:

- Stack #4: Sneak > Left A Gap
- #4: Head Up LS > Sneak A Gaps
- #3: Inside Shoulder G > A Gap
- #2: Outside Shoulder T > B Gap
- #1: Outside W > D Gap





PUNT BLOCK (3-4 OFF)

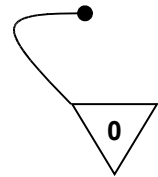
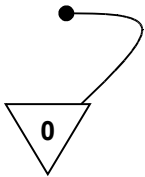

10-12Y Inside

3-4 Off Look

3 Side:

- #3: Inside Shoulder G > A Gap
- #2: Outside Shoulder T > C Gap
- #1: Outside W > D Gap

4 Side:

- Off #4: Sneak > Left A Gap
- #4: Outside Shoulder G > B Gap
- #3: Outside Shoulder T > C Gap
- #2: Outside Shoulder W > D Gap
- #1: Outside > D Gap





PUNT BLOCK (3-4 OFF)

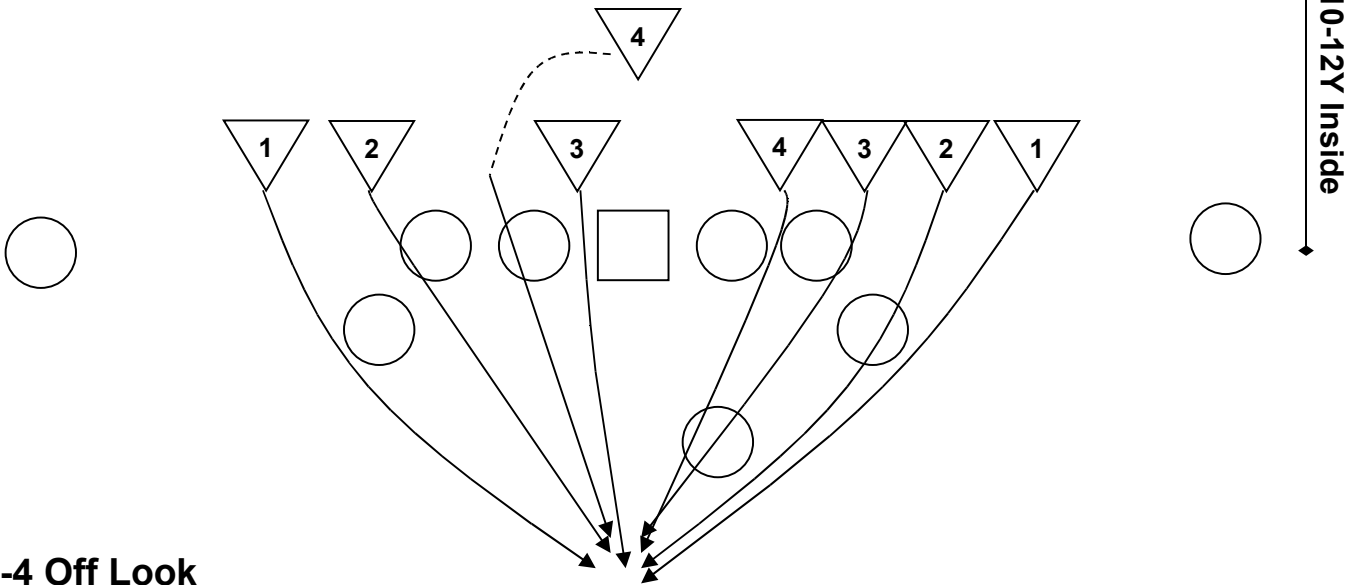

3-4 Off Look

3 Side:

- #3: Inside Shoulder G > A Gap
- #2: Outside Shoulder T > C Gap
- #1: Outside W > D Gap

4 Side:

- Off #4: Sneak > Left B Gap
- #4: Outside Shoulder G > B Gap
- #3: Outside Shoulder T > C Gap
- #2: Outside Shoulder W > D Gap
- #1: Outside > D Gap



PUNT RETURN (4-4 STACK) SINGLE

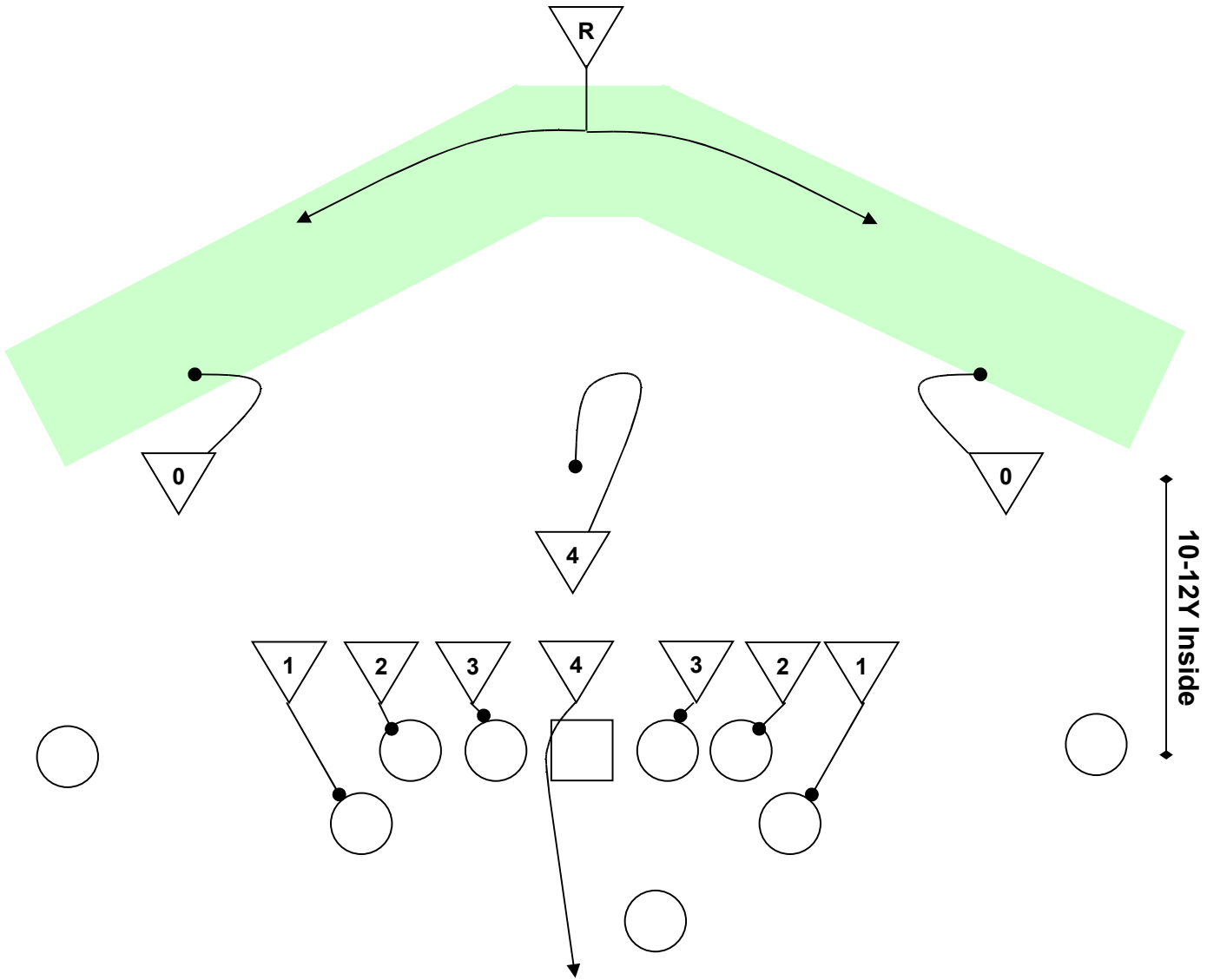

4-4 Stack Look

Right Side:

#4: Head Up LS > Loop Right A Gap Rush

#3: Outside Shoulder G > Hold Up G

#2: Outside Shoulder T > Hold Up T

#1: Outside W > Hold Up W



Left Side:

Stack #4: Pick Up & Block LS

#3: Outside Shoulder G > Hold Up G

#2: Outside Shoulder T > Hold Up T

#1: Outside W > Hold Up W

PR: Run 4 Daylight



PUNT RETURN (4-3 OFF) WALL OFF RIGHT

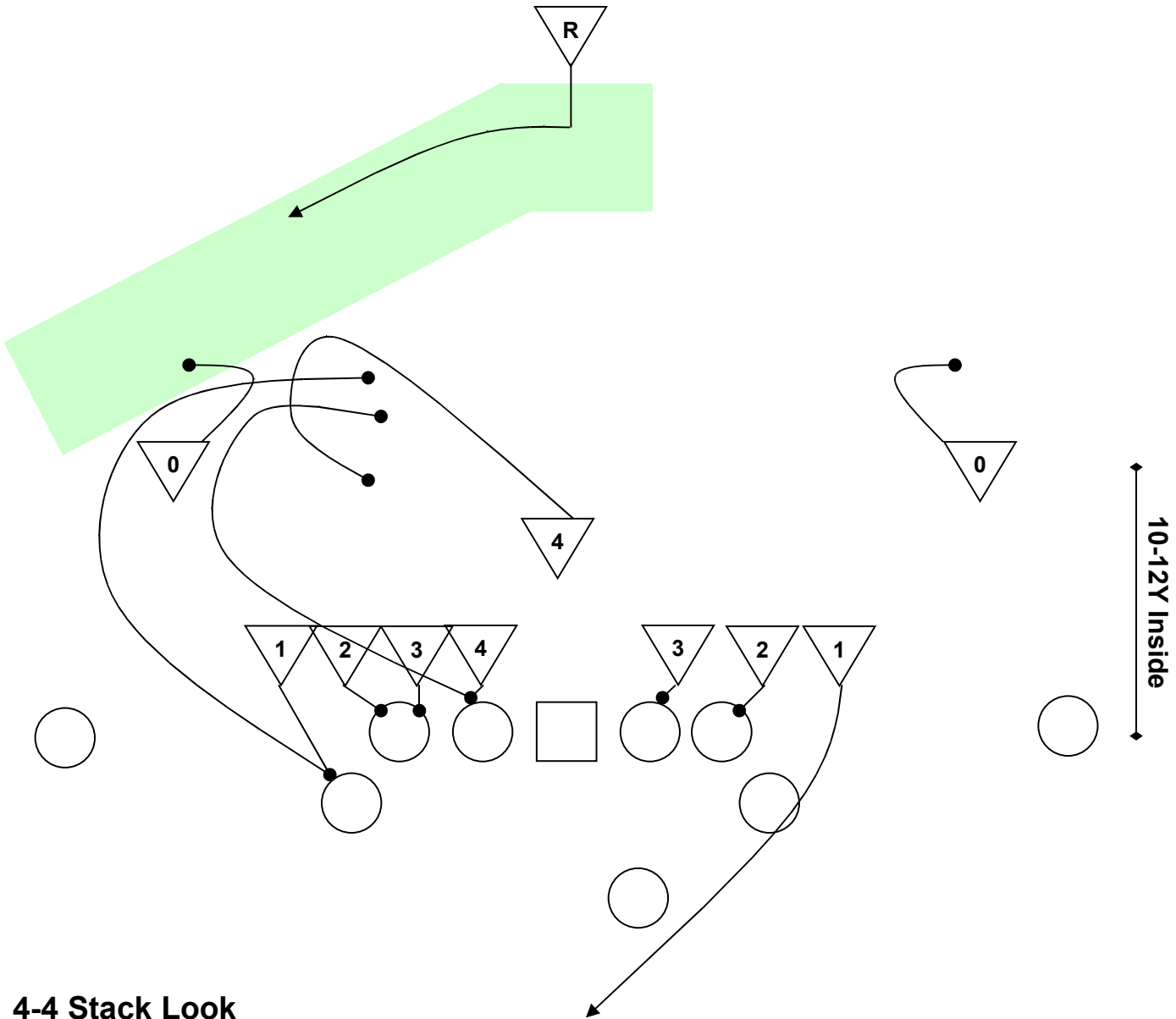

4-4 Stack Look

Right Side:

- #4: Head Up G > Hold Up G > Wall Off
- #3: Inside Shoulder T > Double Team Hold Up T
- #2: Outside Shoulder T > Double Team Hold Up T
- #1: Outside W > Hold Up W > Wall Off

Left Side:

- Off #4: Wall Off
- #3: Outside Shoulder G > Hold Up G
- #2: Outside Shoulder T > Hold Up T
- #1: Outside W > Rush

PR: Run 4 Daylight



SAFE PUNT DEFENSE



Right Side:

#2: Inside Shoulder G > A Gap

#1: Outside Shoulder T > C Gap

Left Side:

#2: Outside Shoulder G > B Gap

#1: Outside W > D Gap





SAFE PUNT DEFENSE FAKE PUNT HAMPTON

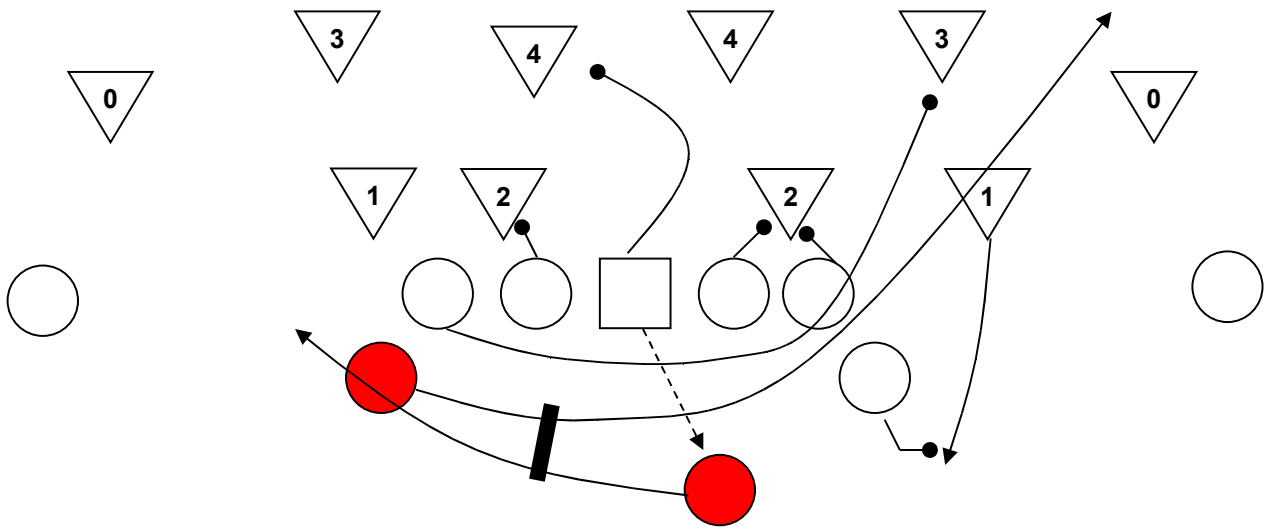



PUNT FAKE PASS DSU

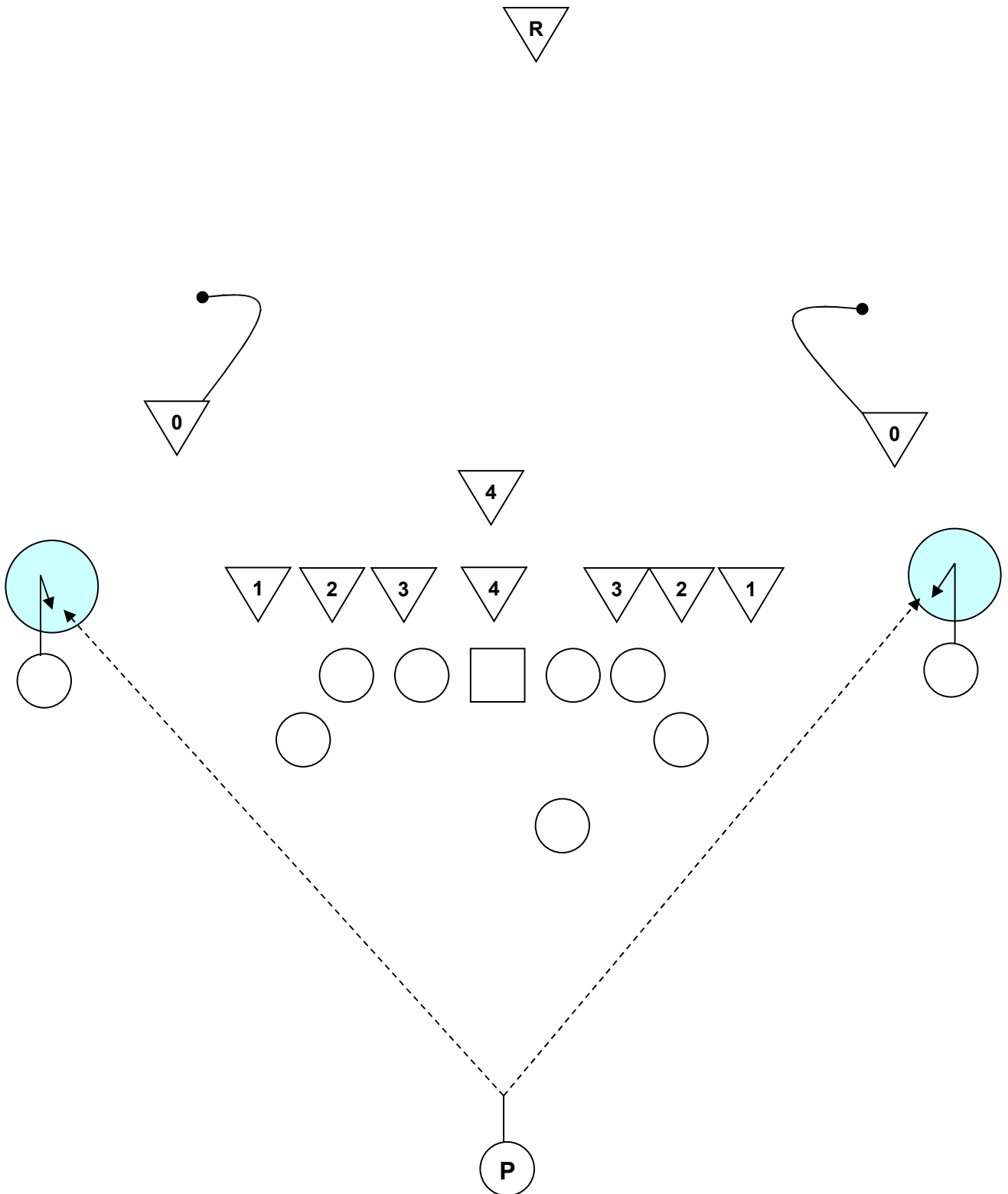



FULL HOUSE WIDE PUNT

36 33

DL

TE

TE

DB

DB

LB

46

LB

DB

DB

SYSTEM ANALYSIS

Full House Wide Formation

PROTECTION

Block Tech: Run Off

Shield Weakness: Man

Protection Block Point: 10Y

behind Wedge Overall Quality: Above

average Punt Unit. Great LS &

average Punter!

LONG SNAPPER

#46 Kelvin Colclough,

RIR Likes to snap the Ball

to the Left > P Off Set, Only Head

Hunter!! Snap 2 Catch:

0,81 - 0,92 sec.

SHIFTS/MOTION

NOPE

SUMMARY

Weakness by Inside

Overloads & Switches.

Weakness 8 Man Inside Rush!

ANY BLOCKED PUNTS?

NOPE

How?

When?

KEY OBSERVATIONS

#36 Aaron Haire didn't

punt the last Game vs. HAM. #33 S.

Grantham (KO Kicker) stepped in.

The Get Off Time is much slower and

the there is no more directional

Punting!

PUNTER

#36 Aaron Haire, SO

Alignment: 15Y

LT/RT Footed: Right

Approach: Straight &

Directional Steps: 3 (Jab, Dribe &

Plant

Get Off: 2,10 - 2,27 sec.

Hang Time: 3,05 - 4,49

sec. Punt Ø: 40,7Y

Sky Punt: Middle

Corner: OOB

Stats: 28-1140

Inside 20: 7

+50Y: 5

Touchbacks: 3

Fair Catch: 4

NET PUNT Ø

36,1Y

COVERAGE

Directional = Slide > Fan

Coverage Straight = Inside-Out Fan

Coverage LS is the only Head Hunter

Punter is cleaning the Field

Good Field Coverage Skills!



PUNT PERSONAL

#36 Aaron Haire
Punter
6-9, 175 Sophomore
Orangeburg, SC (Orangeburg-Wilkinson High)



Enters the fall as the top candidate to handle the punting duties this fall after splitting the chores with two other punters during his freshman campaign in 2006...showed a lot of improvement and confidence during spring drills...Was a standout punter at Orangeburg-Wilkinson High and would give the Bulldogs a great weapon if he shows that same form....**2006:** Started his freshman season as the top punter for the Bulldogs after a solid prep career...Got off to a slow start and eventually gave way to two other punters who rotated the duties, however, he got another chance at the job and finished the campaign as the starter...Had 19 points for 568 yards and a 29.9 average, including a long of 49 yards...An excellent student...earned the prestigious Arthur Ashe Sport Scholar award and was awarded the Dwight D. Eisenhower Fellowship (transportation field)...**High School:** Was the number one punter in the Times and Democrat (newspaper) Region as a senior and the number two punter among punters in state 4-A high schools...**Personal:** Biology major...born December 26, 1986...the son of Bernard and Vemell Haire.

Haire's Season Statistics

Season	No.	Yds.	Avg	Long	TB	FC	I20	Blkd
2006	19	568	29.9	49	1	2	-	-

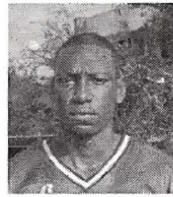

46 Kelvin Colclough
Long Snapper (Special Teams)
6-3, 205 R-Junior
Darlington, SC (Darlington High)

Expected to handle the long snapping duties for field goals, extra points and punts for a second consecutive year...Was very solid in the role last season in all 11 contests...Has added weight and strength which should be a plus...May face some stiff competition from defensive lineman Cedric Lloyd who showed promise as the long snapper in the spring...**2006:** Was the long snapper on field goals, extra points and punts in all 11 of the team's games... Performed well and was very consistent throughout the campaign...**2005:** Was redshirted...**High School:** Eamed three letters during his prep career...**Personal:** A mechanical engineering technology major...born December 29, 1985...the son of Janice and Edward Colclough.

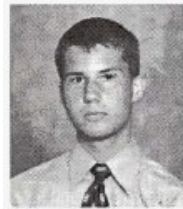

33 Stephen Grantham
Placekicker
6-0, 185 Sophomore
Florence, SC (South Florence High)

Returns to the team in 2007 after being dismissed from the team after spring of 2006 due to academic deficiencies...Is expected to handle the starting placekicking duties as well as kickoffs for the Bulldogs...Has a very strong leg and demonstrated consistency during the 2005 season...**2006:** Was dismissed for the entire season...**2005:** Took over the placekicking duties as a true freshman when senior Michael Gaston broke his leg during preseason drills...Performed well and led the team in scoring with 72 points...Connected on 9-15 field goal attempts, including a lone of 47 yards, and was true on 45-51 extra points...**High School:** Was a two-sport standout, earning three letters in football and four in soccer at South Florence High...Played in the prestigious North-South All-Star contest...Had four extra points and a touchback in his team's 28-13 victory...**Personal:** A nursing major...born April 10, 1987 the son of Don and Sue Grantham

PUNT STATS

PUNTING	No.	Yds	Avg	Long	TB	FC	I20	Blkd
HAIRE, Aaron	28	1140	40.7	61	3	4	7	0
GRANTHAM, S.	6	204	34.0	45	0	0	2	0
Total.....	34	1344	39.5	61	3	4	9	0
Opponents.....	31	1321	42.6	58	4	2	14	0



FH WIDE PUNT PERSONAL

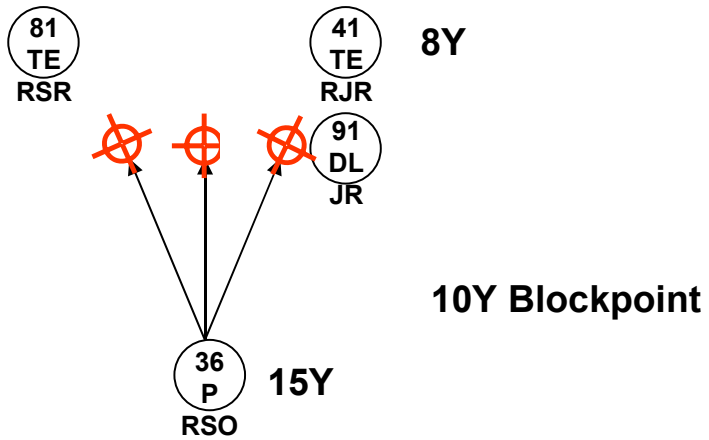
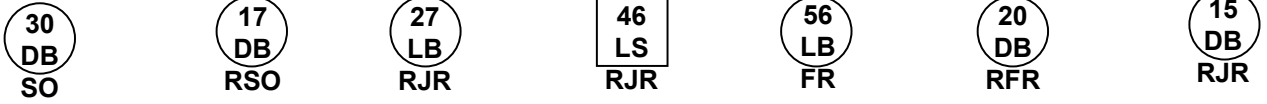



PUNT OPERATIONS

Opp: WSSU
Get Off: 2,27s
Hangtime: 3,27s
Distance: 47Y
Field: SCS50 > WSS03 Downed
Approach: Directional Right

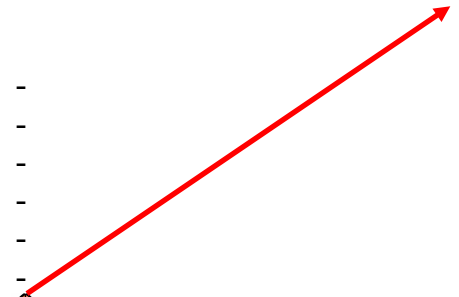

Opp: NSU
Get Off: 2,16s
Hangtime: 3,05s
Distance: 46Y
Field: SCS23 > NSU31 PR13Y
Approach: Straight

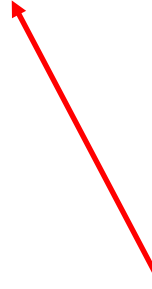

Opp: NSU
Get Off: 2,10s
Hangtime: 4,49s
Distance: 47Y
Field: SCS22 > NSU31 FC
Approach: Directional Right

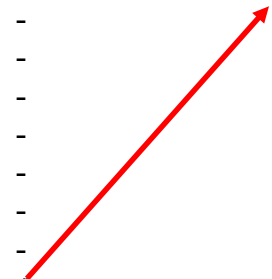

Opp: NSU
Get Off: 1,90s
Hangtime: 4,15s
Distance: 55Y
Field: SCS38 > NSU07 PR22Y
Approach: Straight



Opp: NSU
Get Off: 2,25s
Hangtime: 3,30s
Distance: 52Y
Field: SCS35 > NSU13 PR9Y
Approach: Straight

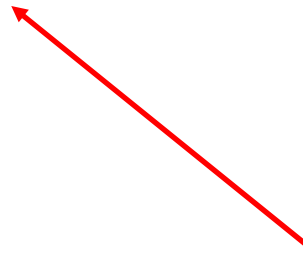



PUNT OPERATIONS

Opp: FAMU
 Get Off: 2,27s
 Hangtime: 3,65s
 Distance: 32Y
 Field: SCS30 > FAM38 OOB
 Approach: Directional Left



Opp: FAMU
 Get Off: 2,16s
 Hangtime: 3,66s
 Distance: 21Y
 Field: FAM44 > FAM23 OOB
 Approach: Straight



Opp: FAMU
 Get Off: 2,20s
 Hangtime: 4,28s
 Distance:
 Field: FLAG! Roughing The Punter!
 Approach: Directional Right



Opp: FAMU
 Get Off: 2,20s
 Hangtime: 3,60s
 Distance: 34Y
 Field: FAM49 > FAMU15 FC
 Approach: Straight



Opp: HAM
 Get Off: 2,28s
 Hangtime: 3,84s
 Distance: 31Y
 Field: HAM35>HAM4 OOB (Corner)
 Punter: #33 S. Grantham





PUNT OPERATIONS

Opp: HAM
 Get Off: 2,27s
 Hangtime: 3,91s
 Distance: 45Y
 Field: SCS39>HAM16 - PR 3Y
 Punter: #33 S. Grantham



Opp: HAM
 Get Off: 2,33s
 Hangtime: 2,99s
 Distance: 34Y
 Field: SCS11>SCS45 (Backed Up)
 Punter: #33 S. Grantham



Opp: HAM
 Get Off: 2,31s
 Hangtime: 2,70s
 Distance: 30Y
 Field: SCS24>HAM46 Downed
 Punter: #33 S. Grantham



Opp: HAM
 Get Off: 2,44s
 Hangtime: 3,49s
 Distance: 34Y
 Field: SCS35>HAM31 Downed
 Punter: #33 S. Grantham



Opp: HAM
 Get Off: 2,20s
 Hangtime: 3,66s
 Distance: 30Y
 Field: SCS35>HAM31 - 72Y PR TD
 Punter: #33 S. Grantham





FH WIDE PUNT PROTECTION vs. 10 (5-5) RUSH

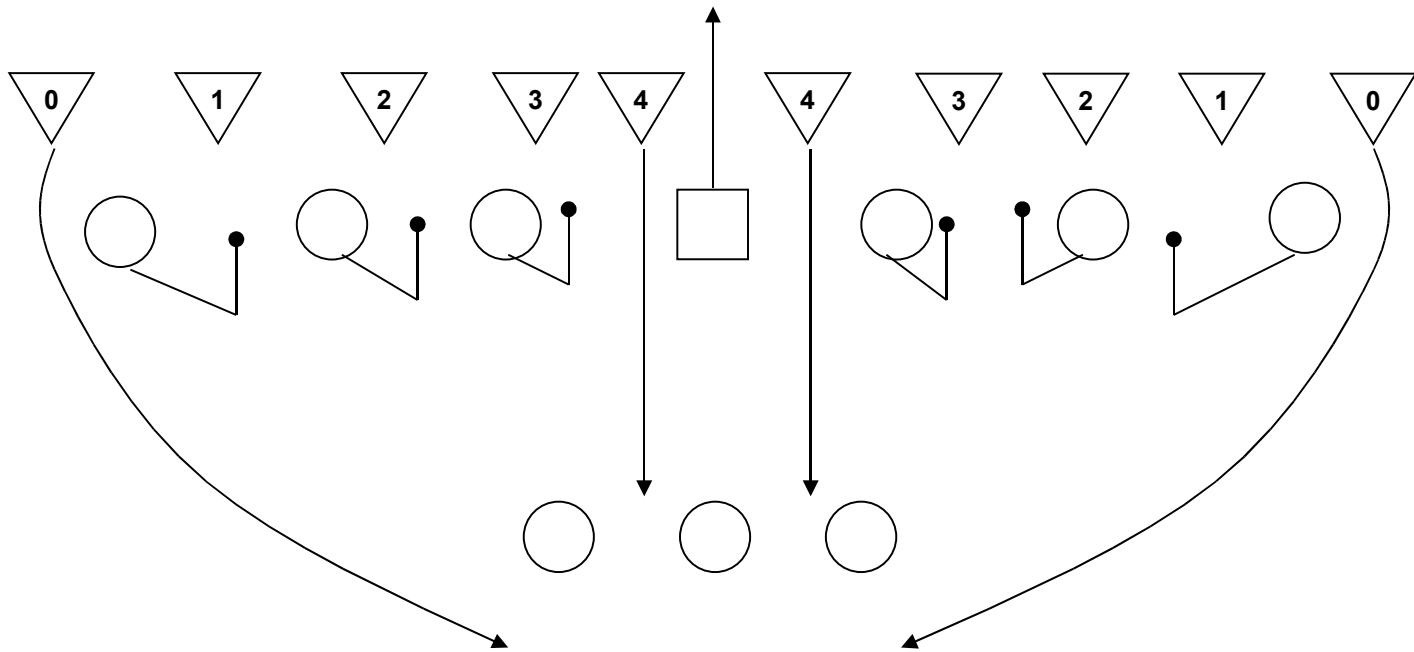

LS: Always Release, Never Blocks > Only Head Hunter

TE: Always #1 > Run Off Shield Tech.

T: Always #2 > Run Off Shield Tech.

G: Always #3 > Run Off Shield Tech.

WEDGE: Always Inside Penetration #4's

No Blocks on #0

Punt Operation Time is too fast to be a Threat

All Front Line Blockers will release immediately if the treath will not rush!!!

Man Protection!!



FH WIDE PUNT PROTECTION vs. 8 (4-4) RUSH

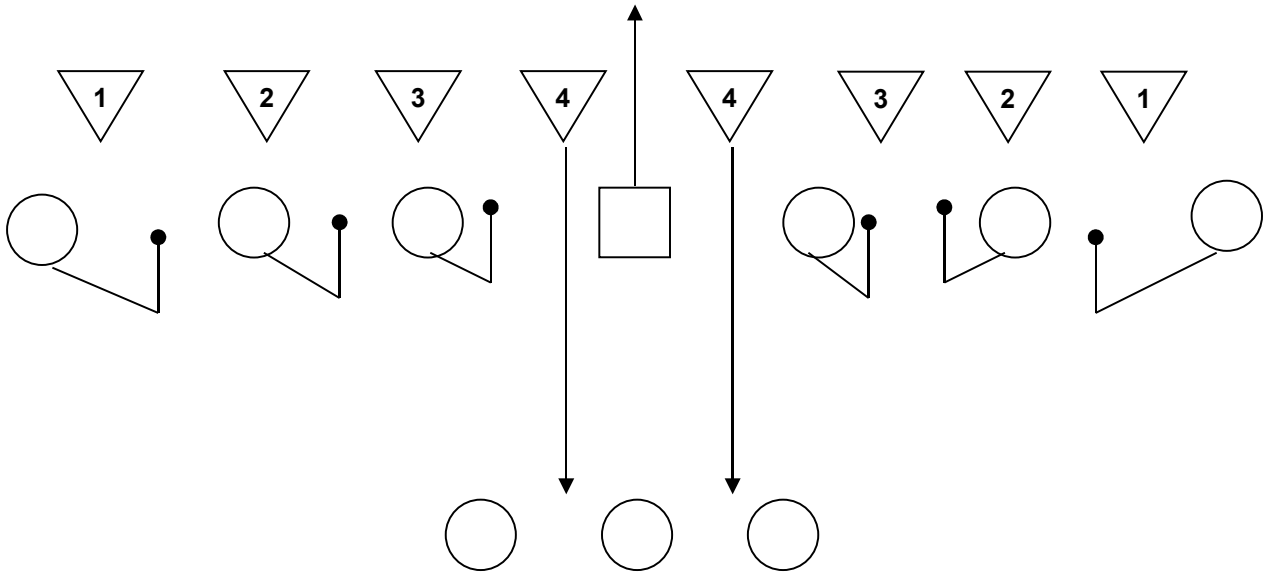

LS: Always Release, Never Blocks > Only Head Hunter

TE: Always #1 > Run Off Shield Tech.

T: Always #2 > Run Off Shield Tech.

G: Always #3 > Run Off Shield Tech.

WEDGE: Always Inside Penetration #4's

All Front Line Blockers will release immediately if the treath will not rush!!!

Man Protection!!



FH WIDE PUNT PROTECTION vs. 8 (4-4) RUSH

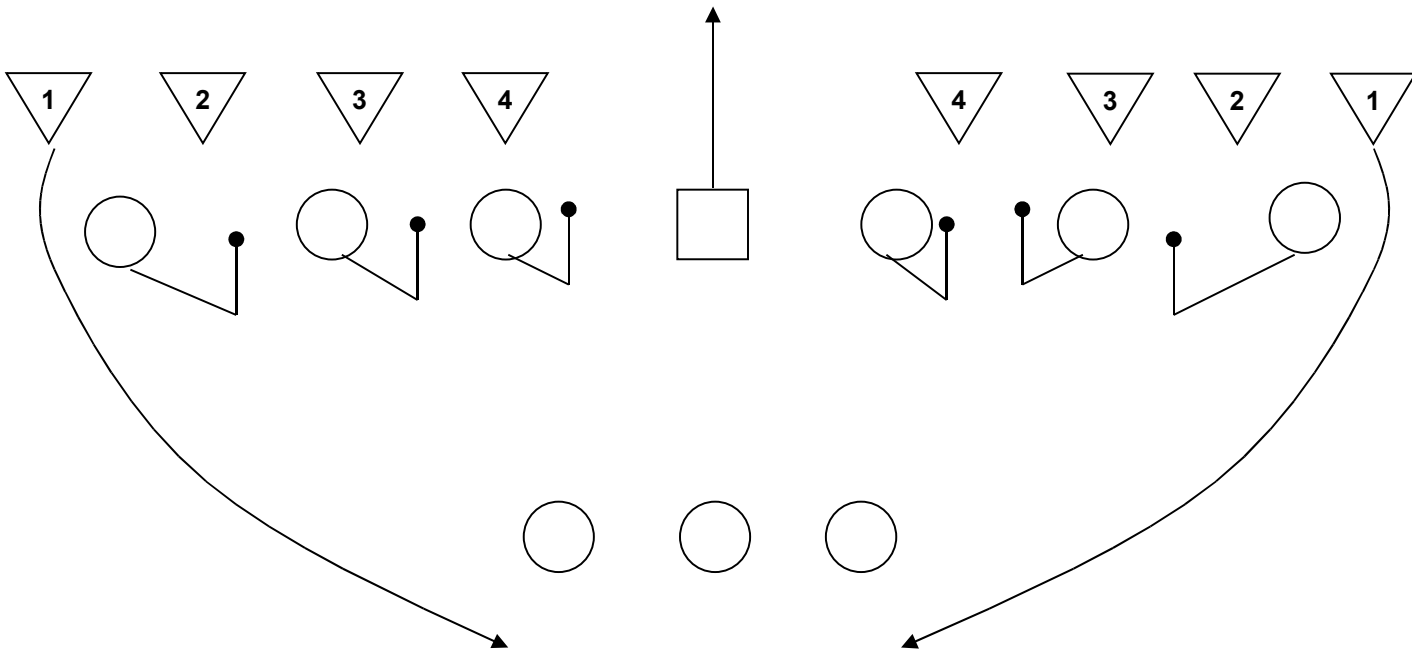

LS: Always Release, Never Blocks > Only Head Hunter

TE: Always #2 > Run Off Shield Tech.

T: Always #3 > Run Off Shield Tech.

G: Always #4 > Run Off Shield Tech.

WEDGE: Always Inside Penetration #4's

No Blocks on #1

Punt Operation Time is too fast to be a Threat

All Front Line Blockers will release immediately if the treath will not rush!!!

Man Protection!!



FULL HOUSE WIDE PUNT COVERAGE DIRECTIONAL RIGHT SLIDE

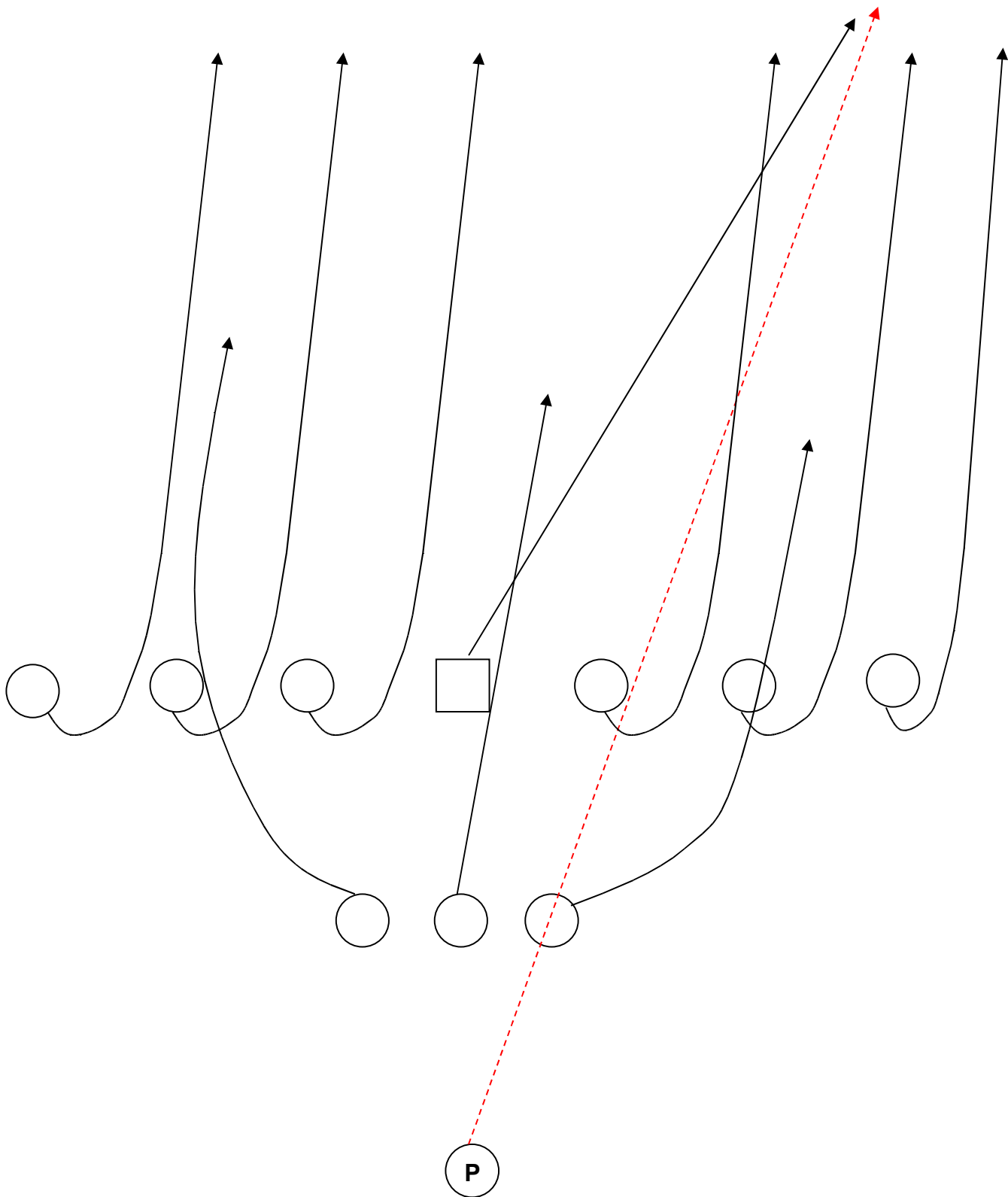



FULL HOUSE WIDE PUNT COVERAGE DIRECTIONAL LEFT SLIDE

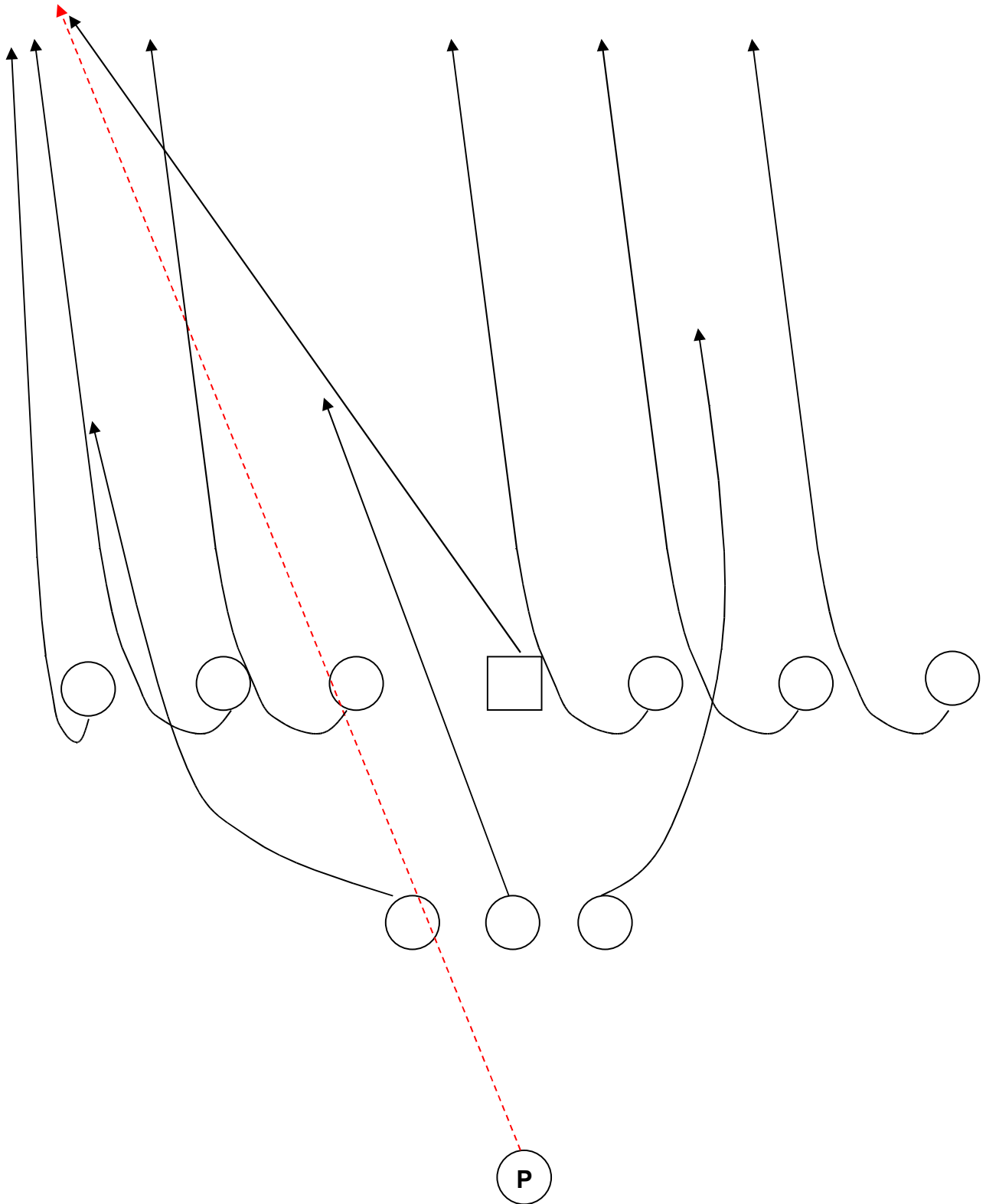



FULL HOUSE WIDE PUNT COVERAGE STRAIGHT

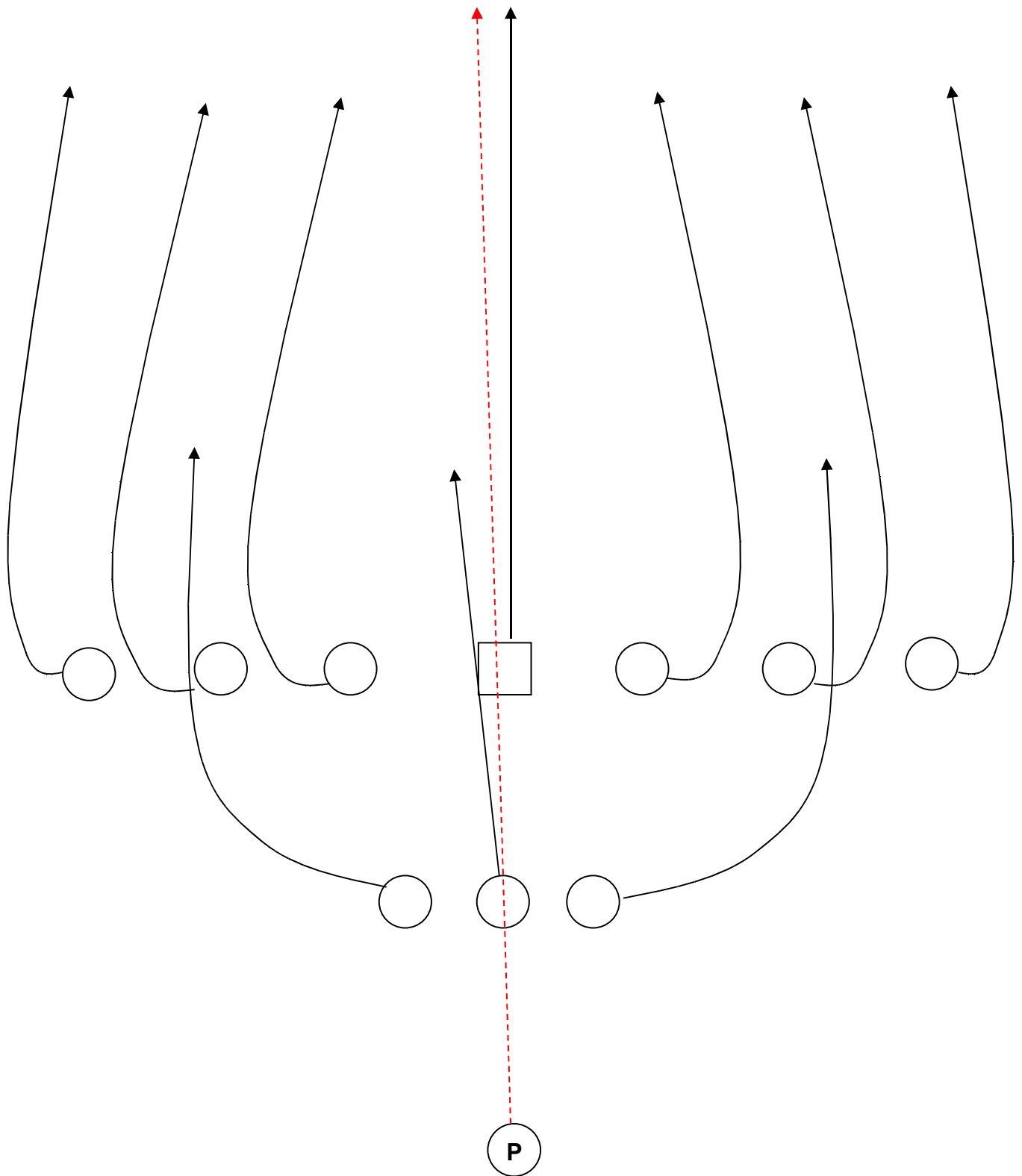



PAT/FG TEAM

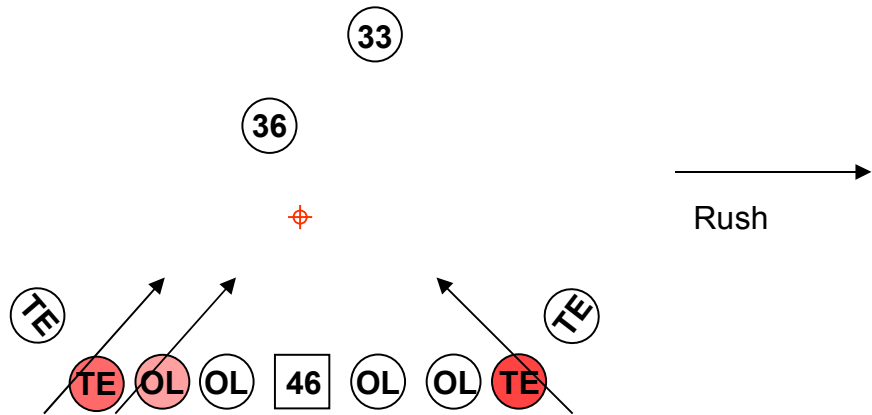

SYSTEM ANALYSIS

Conventional PAT/FG

Unit
UB 45° Angle

Both TE Deep Low

Inside Zone
Step > Both UP Short

Inside
Zone Step

= Can't closed the

Gap!!
PROTECTION

Block Tech: Inside

Zone Punch!
Weakness: Both TE

#86, #81
Block Point: 5Y

Overall Quality: The

Inside
is Very Good. Both TE

are weak
in Blocking & Balance

SHORT SNAPPER

#46 Kelvin Colclough,

RIR
Very fast and good

Snapper.
Average Blocker!

SHIFTS/MOTION

On Hash FG Tackle

Over
Formations!

OPERATIONS

Get Off 1,20 – 1,26 ec.

Ø 1,23 sec.!!

SUMMARY

Very Good Operation

Times
Ø 1,23 sec.!!

Great Short Snapper &

Holder!
No Hash Kicker!

Weak TE's!

Great Inside Protection!

ANY BLOCKED PAT/FG?

YES

How-When? WSSU FG

Left C-Gap Rush (TE #81)

How-When? NSU

Right D-Gap Rush (TE

#86)

KEY OBSERVATIONS

vs. HAM new Holder

#25 Byron Bush, RJR

(WR) is
Bringing both Hands

before the
Snap to the SS. Read for

Take Off!
STATS

PAT's 17-17

FG's 7-17 (6-17)

KICKER

#33 Stephen Grantham,

SO
Alignment: 3-2

LT/RT Footed: Right

Approach: Soccer

Steps: 3 (Jab, Drive &

Plant)
Get Off: 1,20 – 1,26 sec.

Hash Tend: RH>RGP,

LH>LGP
Distance: 51Y vs. Air Force

Under Pressure: Very Stabil

Overall: Good fast PAT

Kicker,
bad FG Kicker. No good

directions
on Hash FG's.

HOLDER

#36 Aaron Haire, SO

(Punter)
Good Ball Handling and

great
Hold Mechanics!

FAKES?

NOPE

COVERAGE

No Releases on FG's

NO Scoop & Score

Coverage on
PAT's



PAT-FG HITTING SPOTS

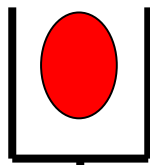

PAT

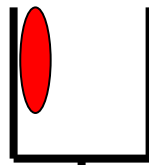

FG

Left Hash

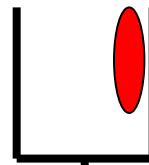

FG

Right Hash

PAT-FG STATS

FIELD GOALS	FGM-FGA	Pct	01-19	20-29	30-39	40-49	50-99	Lg	Blk
GRANTHAM, S.	6-16	37.5	0-0	2-5	3-5	0-4	1-2	51	4
HAIRE, Aaron	1-1	100.0	0-0	0-0	1-1	0-0	0-0	37	0

FG SEQUENCE	South Carolina State	OPPONENTS
Bethune-Cookman	(35), 40, 47, 38	47, (24), 27, (27)
Air Force	49, (51)	(48), (22)
South Carolina	(37)	(40)
Winston-Salem State	50, (28), (38), 27	52
Norfolk State	35, (38), (22), 29, 42	(42), (31), 42, 54, 32
Florida A&M	-	-
Hampton	23	(33)

Numbers in (parentheses) indicate field goal was made.

FIELD GOALS-ATTEMPTS.....	7-17
PAT-ATTEMPTS.....	17-17



TACKLE OVER FG FORMATION

Right Hash:

Right Tackle Over

Off Set Snap

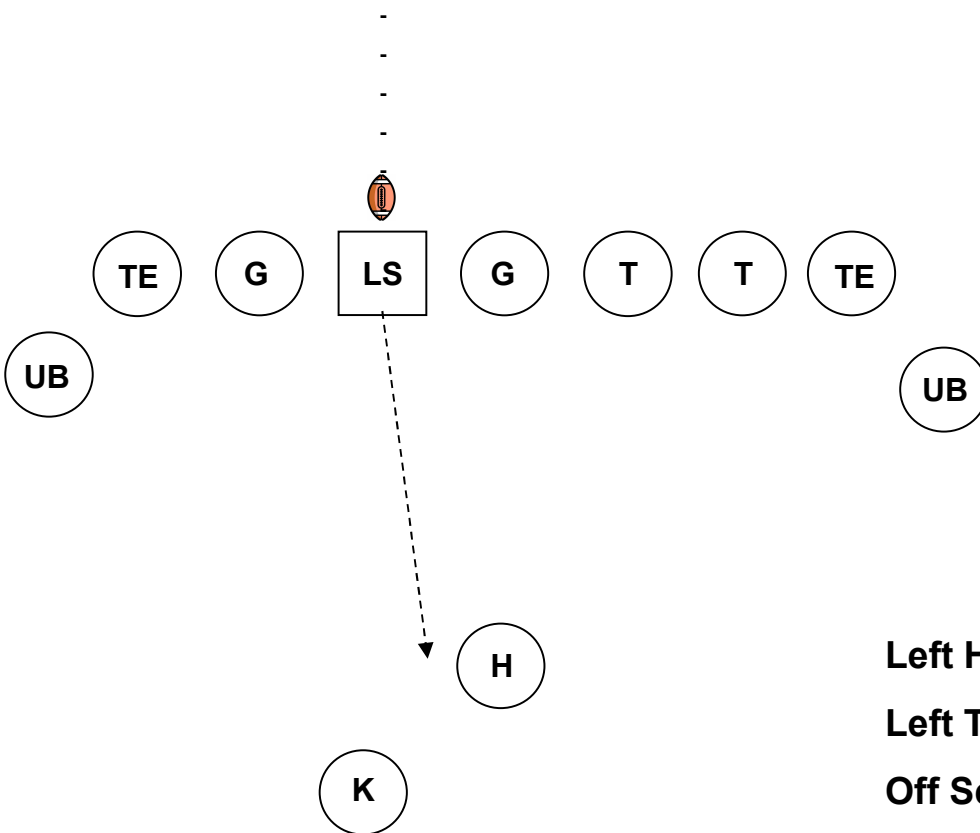
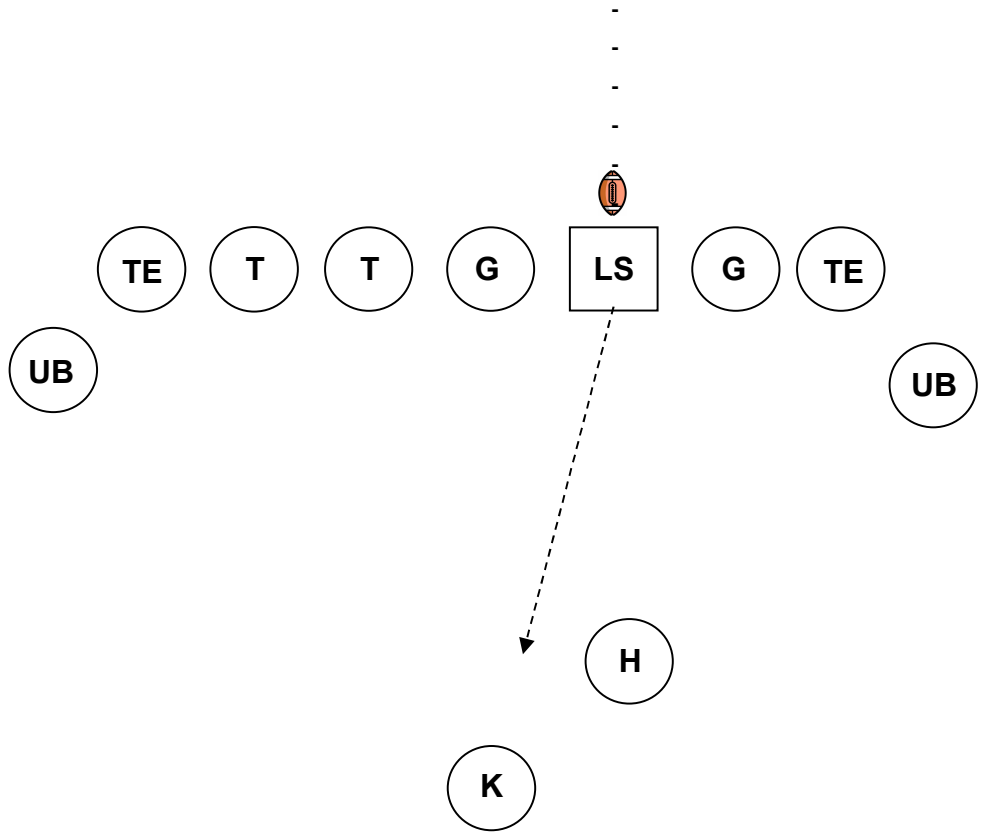

Left Hash:

Left Tackle Over

Off Set Snap



PAT-FG PERSONAL



33 Stephen Grantham
Placekicker
6-0, 185 Sophomore
Florence, SC (South Florence High)

Returns to the team in 2007 after being dismissed from the team after spring of 2006 due to academic deficiencies...Is expected to handle the starting placekicking duties as well as kickoffs for the Bulldogs...Has a very strong leg and demonstrated consistency during the 2005 season...**2006:** Was dismissed for the entire season...**2005:** Took over the placekicking duties as a true freshman when senior Michael Gaston broke his leg during preseason drills...Performed well and led the team in scoring with 72 points...Connected on 9-15 field goal attempts, including a lone of 47 yards, and was true on 45-51 extra points...**High School:** Was a two-sport standout, earning three letters in football and four in soccer at South Florence High...Played in the prestigious North-South All-Star contest...Had four extra points and a touchback in his team's 28-13 victory...**Personal:** A nursing major...born April 10, 1987 the son of Don and Sue Grantham

Grantham's Season Statistics

Season	Field Goals		PATs		
	Att.	Made	Long	Att.	Made
2005	15	9	47	51	45

#36 Aaron Haire
Punter
6-9, 175 Sophomore
Orangeburg, SC (Orangeburg-Wilkinson High)



Enters the fall as the top candidate to handle the punting duties this fall after splitting the chores with two other punters during his freshman campaign in 2006...showed a lot of improvement and confidence during spring drills...Was a standout punter at Orangeburg-Wilkinson High and would give the Bulldogs a great weapon if he shows that same form...**2006:** Started his freshman season as the top punter for the Bulldogs after a solid prep career...Got off to a slow start and eventually gave way to two other punters who rotated the duties, however, he got another chance at the job and finished the campaign as the starter...Had 19 points for 568 yards and a 29.9 average, including a long of 49 yards...An excellent student...earned the prestigious Arthur Ashe Sport Scholar award and was awarded the Dwight D. Eisenhower Fellowship (transportation field)...**High School:** Was the number one punter in the Times and Democrat (newspaper) Region as a senior and the number two punter among punters in state 4-A high schools...**Personal:** Biology major...born December 26, 1986...the son of Bernard and Vernell Haire.

Haire's Season Statistics

Season	No.	Yds.	Avg	Long	TB	FC	120	Blkd
2006	19	568	29.9	49	1	2	-	-

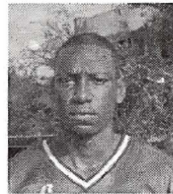

46 Kelvin Colclough
Long Snapper (Special Teams)
6-3, 205 R-Junior
Darlington, SC (Darlington High)

Expected to handle the long snapping duties for field goals, extra points and punts for a second consecutive year...Was very solid in the role last season in all 11 contests...Has added weight and strength which should be a plus...May face some stiff competition from defensive lineman Cedric Lloyd who showed promise as the long snapper in the spring...**2006:** Was the long snapper on field goals, extra points and punts in all 11 of the team's games... Performed well and was very consistent throughout the campaign...**2005:** Was redshirted...**High School:** Eamed three letters during his prep career...**Personal:** A mechanical engineering technology major...born December 29, 1985...the son of Janice and Edward Colclough.



FG BLOCK 5-5 (RIGHT HASH)

Block FG vs. WSSU
Blockside #4

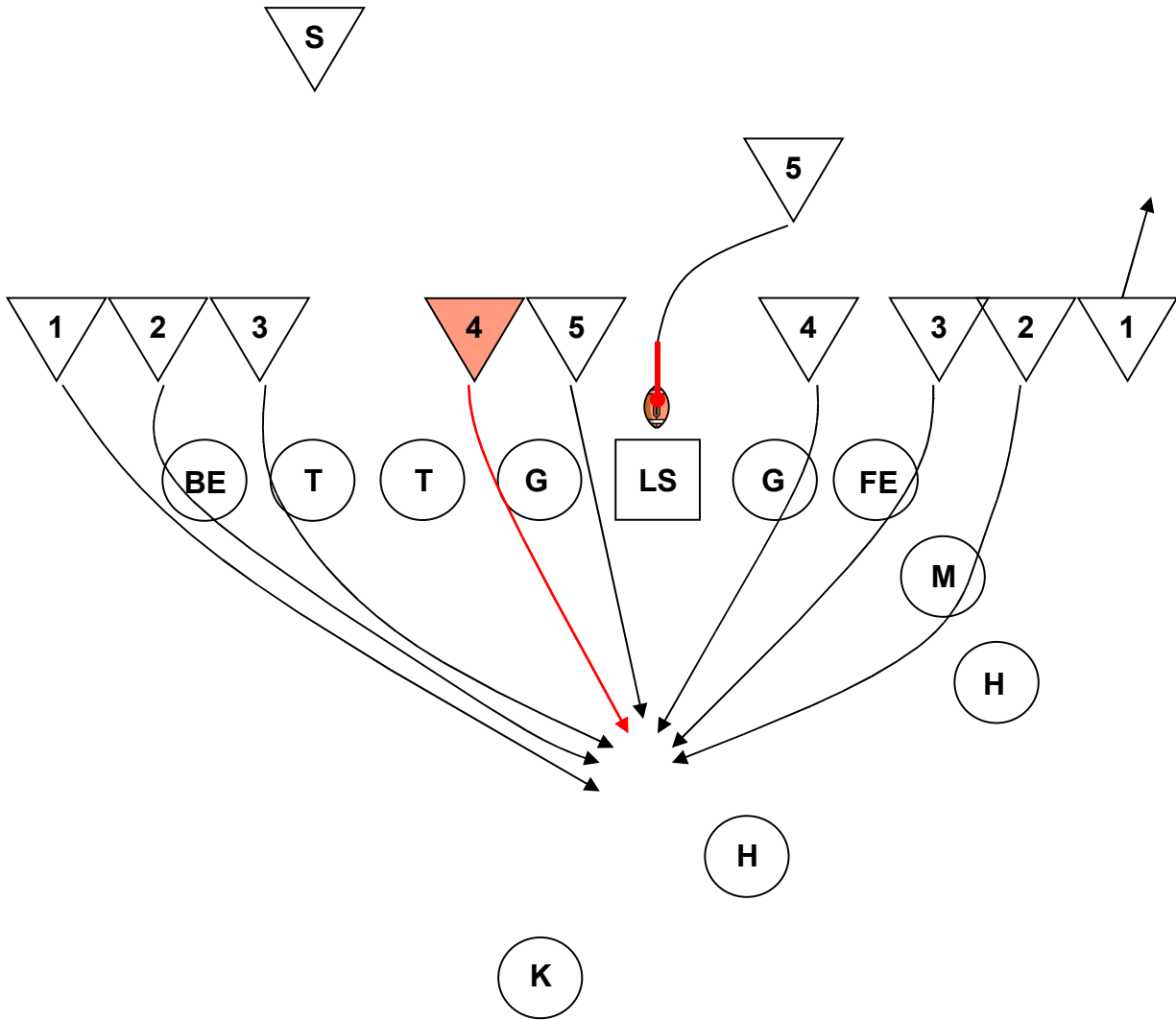

Block Side:

- #1 Outside Rush (E)
- #2 Outside Rush (E)
- #3 Outside Shoulder T Rush (D)
- #4 Outside Shoulder G Rush (B)
- #5 Inside Shoulder G Rush (A)

Scoop & Score Side:

- #1 Outside H Safety
- #2 Outside M Rush (D)
- #3 Outside Shoulder FE Rush (C)
- #4 Outside Shoulder G Rush (B)
- Far #5 Middle Jumper



FG BLOCK 7-4 (LEFT HASH)

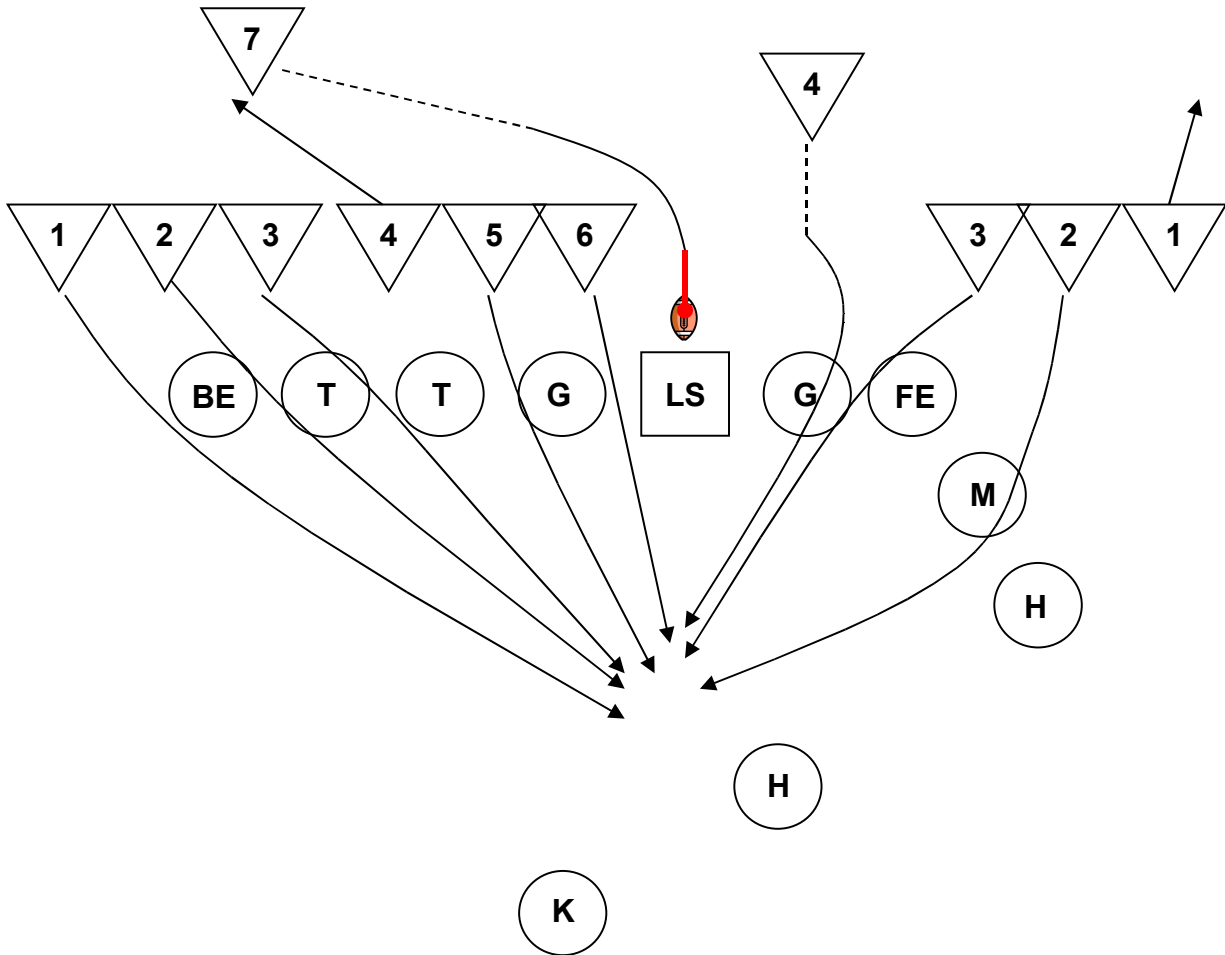

Block Side:

- #1 Outside Rush (E)
- #2 Outside Shoulder BE Rush (D)
- #3 Outside Shoulder T Rush (C)
- #4 Outside Shoulder T Safety
- #5 Outside Shoulder G Rush (B)
- #6 Inside Shoulder G Rush (A)
- #7 Sneek In Middle Jumper

Scoop & Score Side:

- #1 Outside H Safety
- #2 Outside M Rush (D)
- #3 Outside Shoulder FE Rush (B)
- #4 Sneek In Outside Shoulder G Rush (B)



PAT BLOCK 5-6

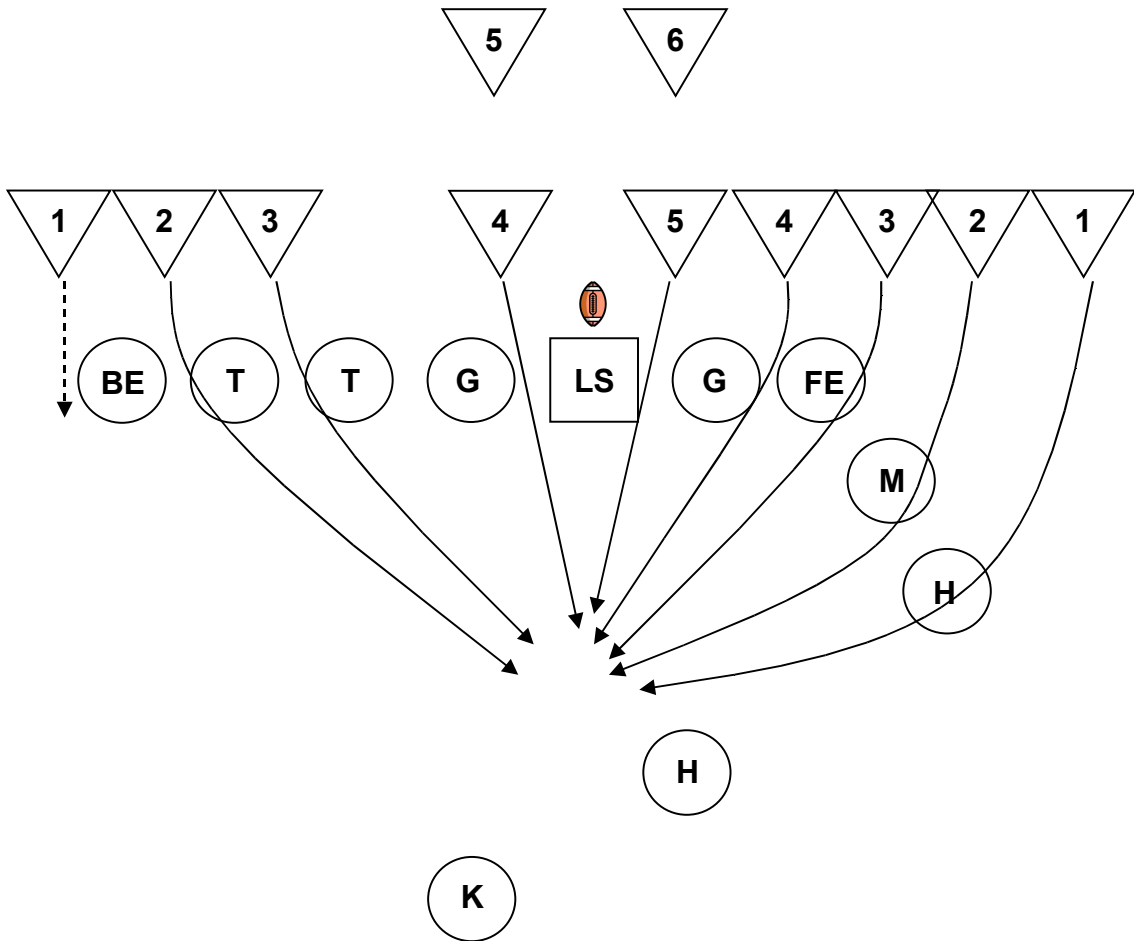

Block Side:

- #1 Outside Shoulder H Rush (F)
- #2 Outside Shoulder M Rush (E)
- #3 Outside Shoulder FE Rush (D)
- #4 Outside Shoulder G Rush (B)
- #5 Inside Shoulder G Rush (A)
- #6 Safety

Scoop & Score Side:

- #1 Scoop & Score
- #2 Outside Shoulder T Rush (D)
- #3 Outside Shoulder T Rush (C)
- #4 Inside Shoulder G Rush (A)
- #5 Safety



PAT BLOCK 6-5

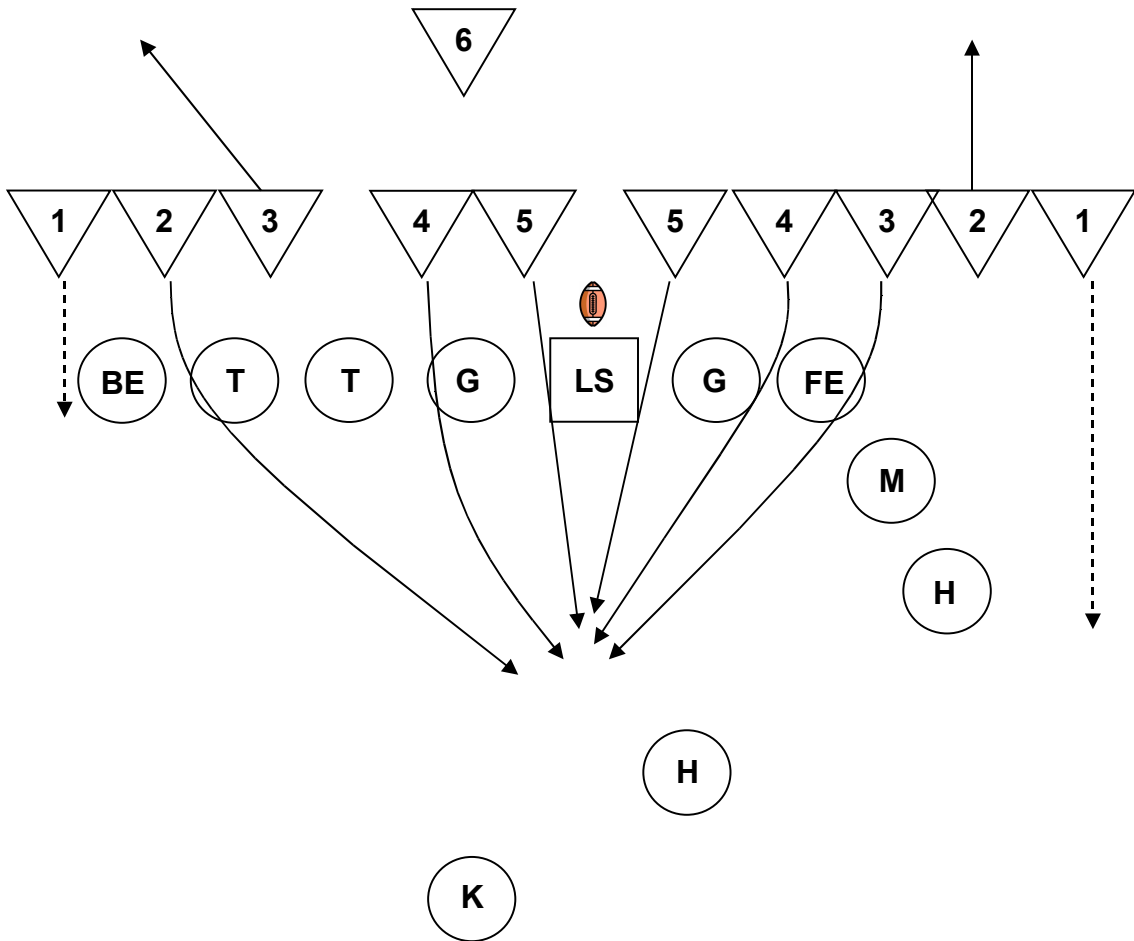

Block Side:

- #1 Outside Shoulder BE S&S
- #2 Outside Shoulder T Rush (D)
- #3 Outside Shoulder T Safety
- #4 Outside Shoulder G Rush (B)
- #5 Inside Shoulder G Rush (A)
- #6 Safety

Scoop & Score Side:

- #1 Scoop & Score
- #2 Outside Shoulder M Safety
- #3 Outside Shoulder FE Rush (C)
- #4 Outside Shoulder G Rush (B)
- #5 Inside Shoulder G Rush (A)



PAT BLOCK TRIPLE JUMPER

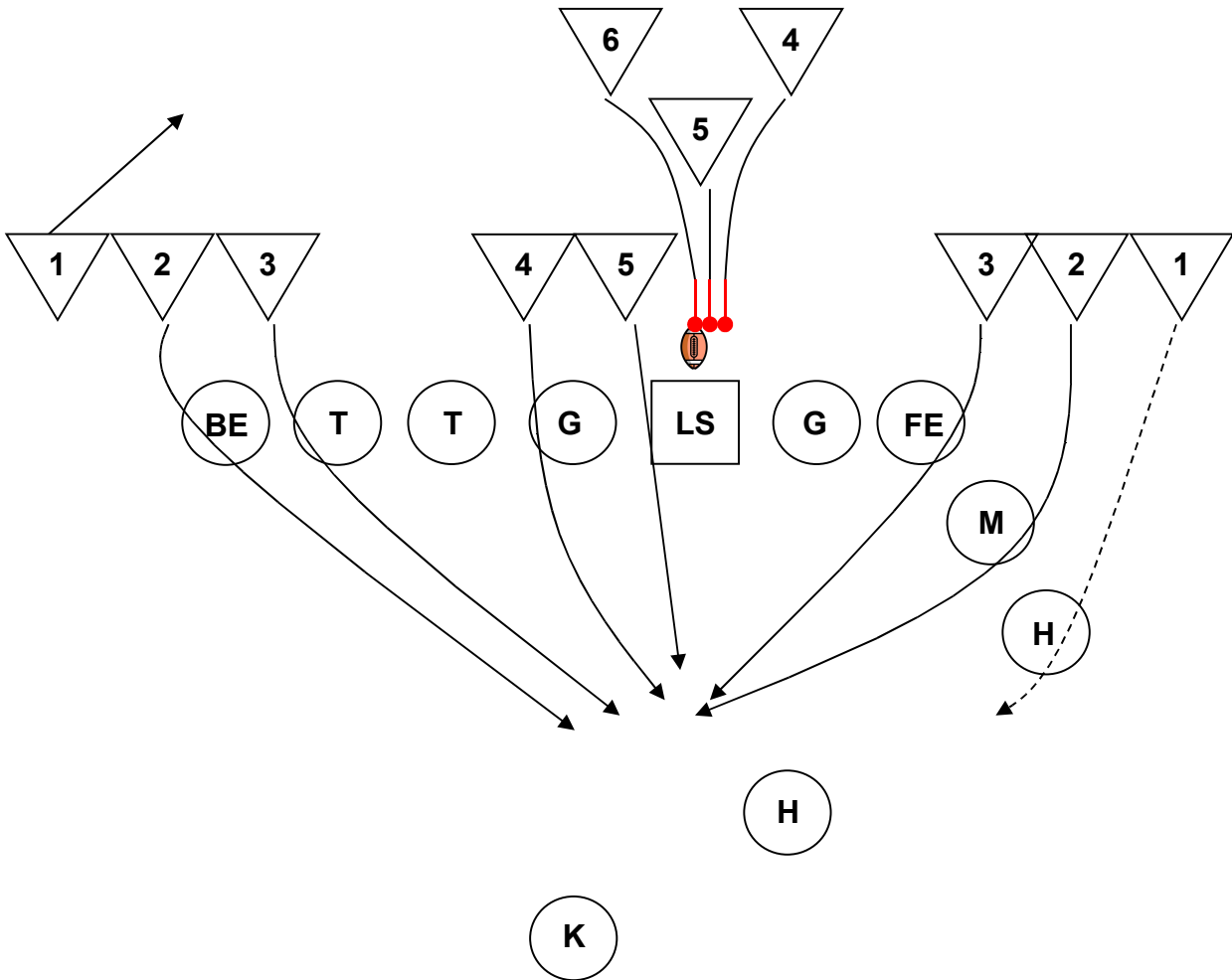

Block Side:

- #1 Outside Safety
- #2 Outside Shoulder BE Rush (E)
- #3 Outside Shoulder T Rush (D)
- #4 Outside Shoulder G Rush (B)
- #5 Inside Shoulder G Rush (A)
- #6 Sneek In Middle Jumper

Scoop & Score Side:

- #1 Scoop & Score
- #2 Outside Shoulder M Rush (D)
- #3 Outside Shoulder FE Rush (C)
- #4 Sneek In Middle Jumper
- #5 Sneek In Middle Jumper



KICK OFF TEAM

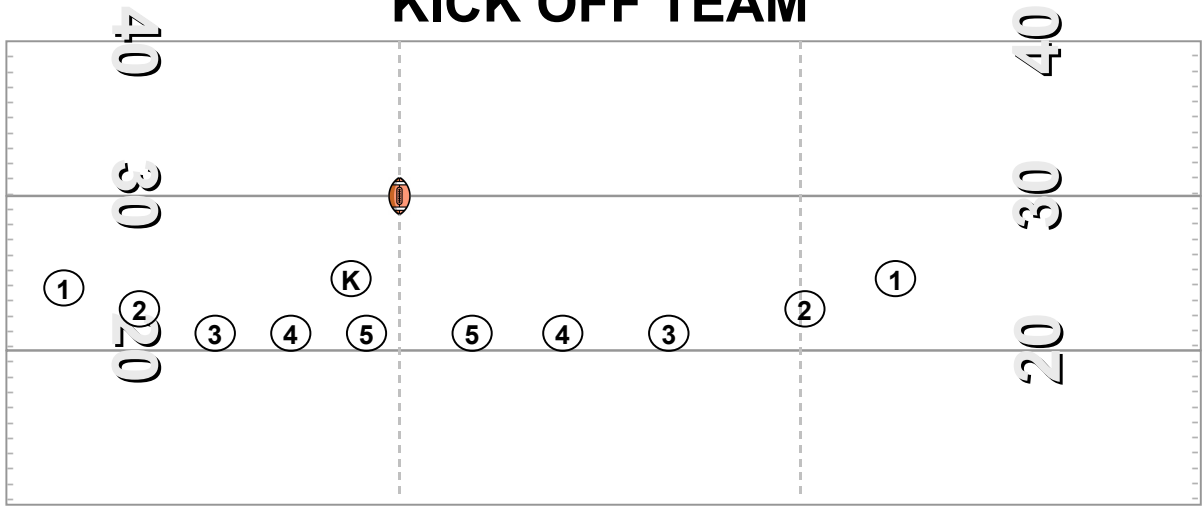

SYSTEM ANALYSIS

The Bulldogs are a balanced (5x5) Unit that kicked the Ball always from the left Hash. The Balls will be placed Deep Left, Deep Middle & Pooch Right!
KICKER

Approach: 7 Steps

Direction: Deep L&M, Pooch R
Hang Time: 3,08 – 4,06 sec.
Distance: Ø 59Y

LT/RT Footed: Right

Onside Ability: Yes

COVERAGE

The Bulldogs have a very fast and good tackling cover team. They are very aggressive and All of them looking for making the play.

BEST COVER MEN

L2 (8T)- R5 (4T)

L1-L3-L5 (3T)

SUMMARY

The Bulldogs are a very good cover Team with great speed and a lot of Courage. The Kicker is average and The weakest link in this unit. All players a very good open field Tackler!

Ø RETURN vs. THEM

21-504Y

Ø 24Y

Long 98Y, 1 TD

Ø START vs. THEM

-33YL

KEY OBSERVATIONS

SAFETIES

L1 > Contain Left, R2 > Contain Right, R1 > Safety, Kicker is cleaning the Field!

ONSIDE KICKS

NOPE

Score of Game:

Time Remaining:

Suprise?:

Alignment:

Courage:

Overall Ability:

STATS

26-1531Y

Ø 58,9Y

1 Touchback, 3 OOB

TOTALS

28-1649Y

Ø 58,9Y, 1 Touchback, 3 OOB

SPECIALS

The Kicker has always the same Approach for Left, Middle & Pooch!



KICK OFF PERSONAL



33 Stephen Grantham
Placekicker
6-0, 185 Sophomore
Florence, SC (South Florence High)

Returns to the team in 2007 after being dismissed from the team after spring of 2006 due to academic deficiencies... Is expected to handle the starting placekicking duties as well as kickoffs for the Bulldogs... Has a very strong leg and demonstrated consistency during the 2005 season... **2006:** Was dismissed for the entire season... **2005:** Took over the placekicking duties as a true freshman when senior Michael Gaston broke his leg during preseason drills... Performed well and led the team in scoring with 72 points... Connected on 9-15 field goal attempts, including a lone of 47 yards, and was true on 45-51 extra points... **High School:** Was a two-sport standout, earning three letters in football and four in soccer at South Florence High... Played in the prestigious North-South All-Star contest... Had four extra points and a touchback in his team's 28-13 victory... **Personal:** A nursing major... born April 10, 1987 the son of Don and Sue Grantham

Grantham's Season Statistics

Season	Field Goals		PATs		Made
	Att.	Made	Long	Att.	
2005	15	9	47	51	45

KICK OFF STATS

KICKOFFS	No.	Yds	Avg	TB	OB	Retn	Net	YdLn
GRANTHAM, S.	26	1531	58.9	1	1			
HAIRE, Aaron	2	118	59.0	0	0			
Total.....	28	1649	58.9	1	1	638	36.1	28
Opponents.....	32	1912	59.8	4	0	754	36.2	28



KICK OFF COVERAGE DEEP LEFT - MIDDLE

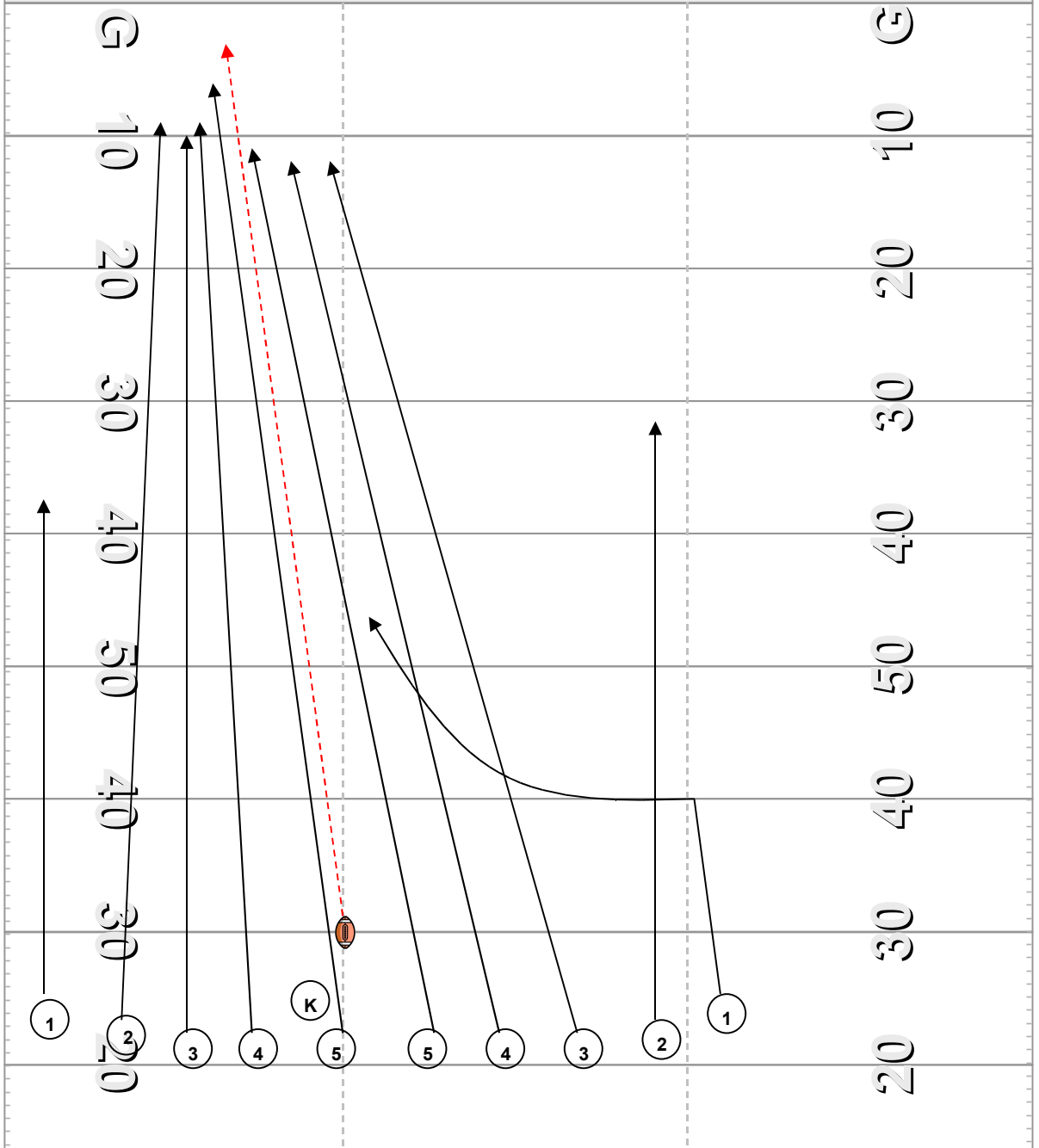

- 5-5 Look
- Ball: Left Hash
- R1: Outside Contain > Safety
- R2-R5: Ball
- Kicker: Is Cleaning the Field
- L3-L5: Ball
- L2: Outside Contain
- L1: Safety



KICK OFF COVERAGE DEEP LEFT - POOCH

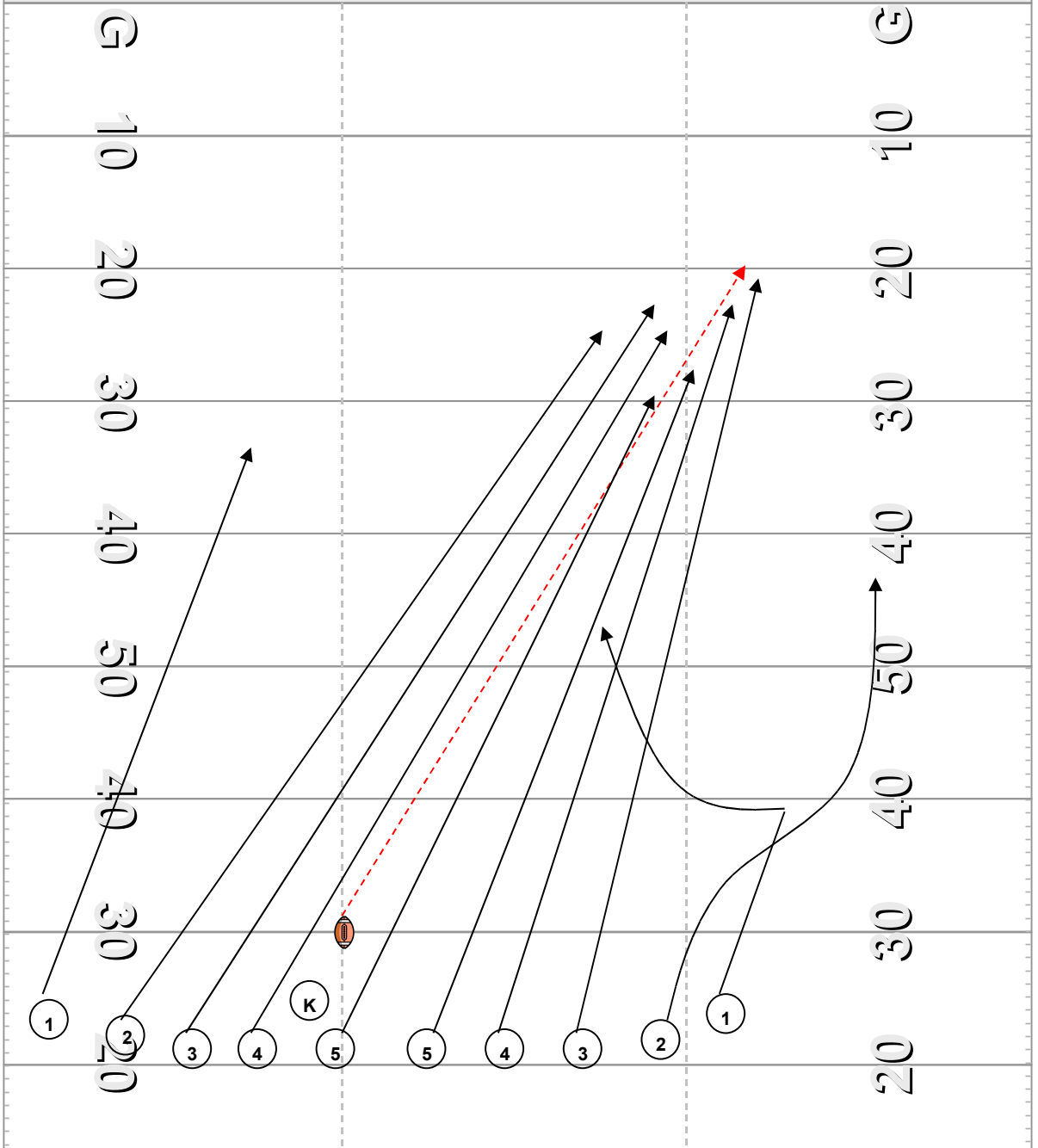

- 5-5 Look
- Ball: Left Hash
- R1: Outside Contain > Safety
- R2-R5: Ball
- Kicker: Is Cleaning the Field
- L3-L5: Ball
- L2: Outside Contain
- L1: Safety



KICK OFF SPOTS

18-22-23

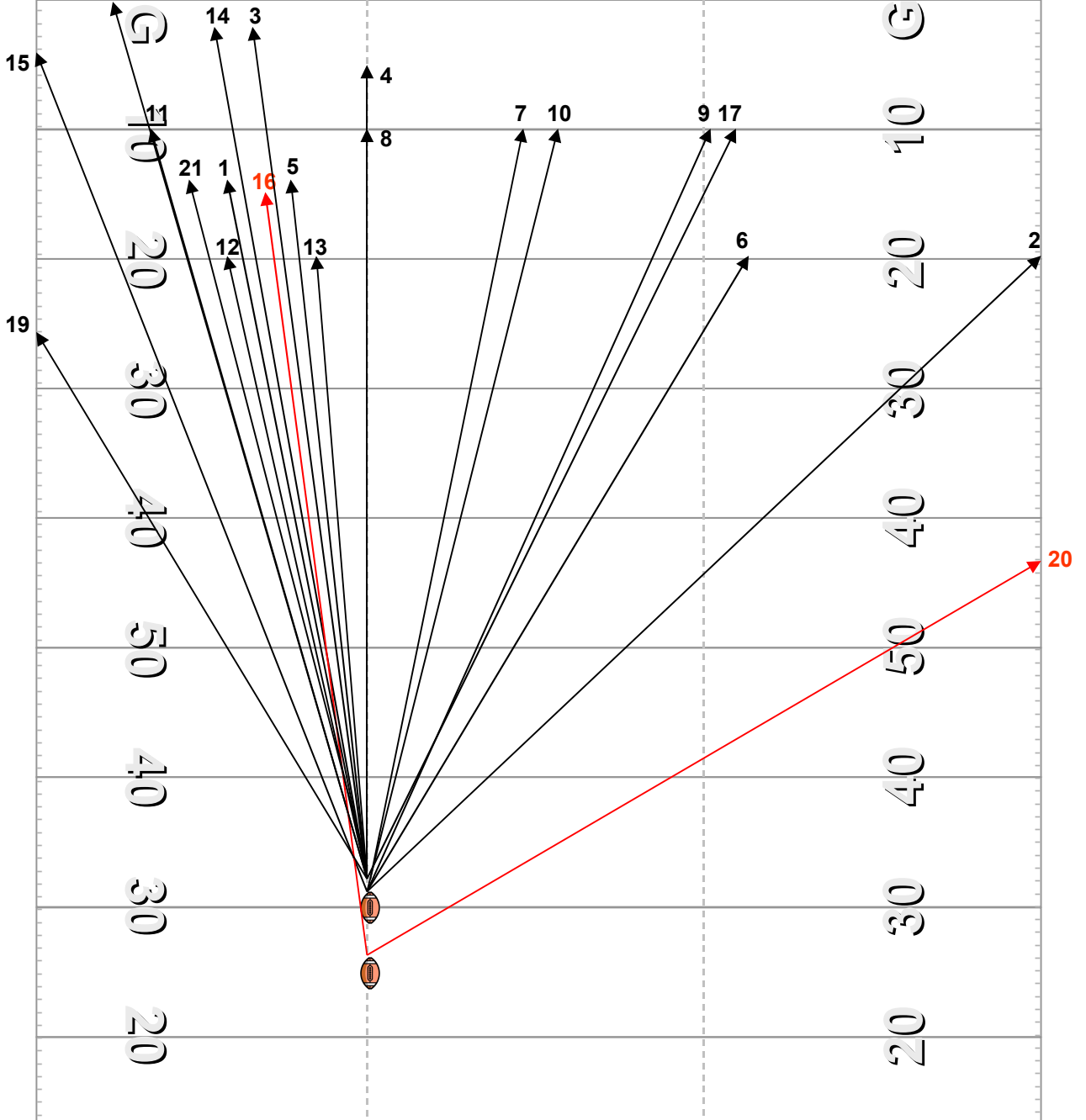

	1	2	3	4	5	6	7	8	9	10	11	12	13	14	15	16	17	18	19	20	21	22	23
Ha sh	L	L	L	L	L	L	L	L	L	L	L	L	L	L	L	L	L	L	L	L	L	L	L
HT	3, 52	3, 59	3, 72	4, 06	3, 08	3, 69	3, 66	3, 80	3, 90	3, 58	4, 03	3, 02	3, 05	3, 29		3, 77	3, 88	4, 14	-	-	2, 88	3, 60	3, 42
TK	L5 R 5	O O B	L1 L2	L5 R4	L2 L3	K	L2 L1	K	L5	R5 L2	L2	L2 L3	R5 R1	L2	O O B	L1 R5	L3 R2	R3	O O B	O O B	R1	L2	R1
K ICK	D L	P O	DL	DL	S Q	P O	D M	D M	D M	D M	DL	S Q	S Q	DL	DL	DL	D M	DL	DL	P O	DL	DL	DL
OP P	W S S	W S S	W S S	W S S	W S S	FA M	FA M	FA M	FA M	FA M	FA M	FA M	FA M	NS U	NS U	NS U	N S U	H A M	H A M	H A M	HA M	H A M	H A M



KICK OFF RETURN TEAM

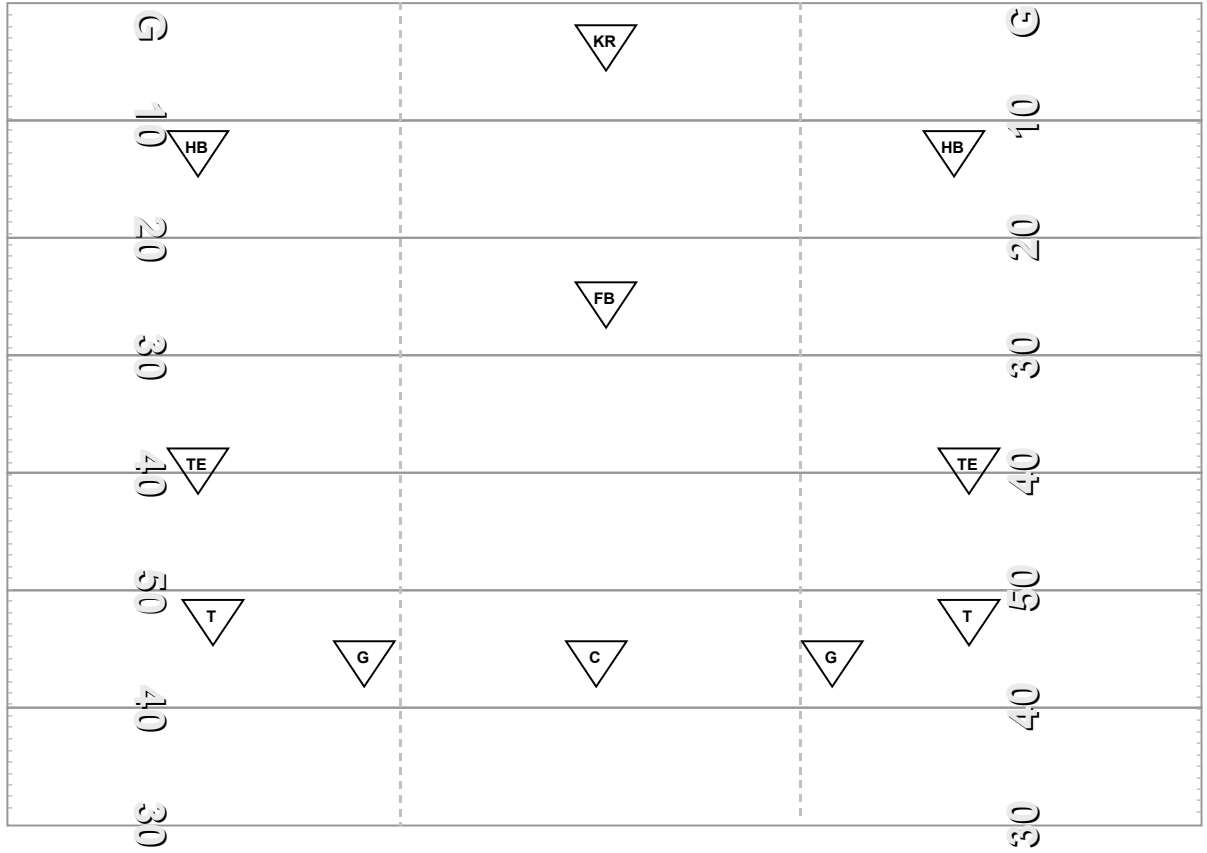

SYSTEM ANALYSIS

The Bulldogs KOR Unit runs a Sideline Return. The T/TE will Double #3 and the FB & HB's will form a Wedge. The Back-Side T will peel off the Kicker!

RETURNERS

#2 Dustin Dubose, RJR, WPR
 Good Hands, Great Speed
 Great Courage, Great Open Field Abilities

STATS

#2 14-404 - Ø 28,9Y
 Loggest 65Y, TD 0

TOTALS

27-674
 Ø 25Y

SUMMARY

Average Blocking Unit with good Speed. Very physical. They are Flying over the Field to set up the Blocks. Great Returner with a solid Wedge. Kicker will be picked up!

RETURN INDICATORS

FB is leading the Wedge to the Ball.
 Stay TE > Return Side
 Fly TE > Back Side
 Center is flying to the Return Side

ALERTS

10 Sideline Return Right
 1 Sideline Return Right

KEY OBSERVATIONS

VULNERABLE TO SURPRICE
 ONSIDE?
 YES

Where?
 Sideline 43YL
 How? East & West Berlin

VULNERABLE TO BLOOP
 KICK?
 YES

Where?
 Sideline 25Y Line
 How?
 Pooch Right & Left



PERSONAL KICK RETURNER



#2 Dusten Dubose
Wide Receiver
5-9, 165 R-Junior
Darlington, SC (Darlington High)

One of the most talented wide receivers on the 2007 squad... The likely starter at the inside receiver position and should play an integral part in the Bulldog offense this season... The quiet leader of the SC State receiving corps and possesses "big play" ability... Has also been among the top performers on special teams... Should reap All-MEAC honors... **2006:** Was the team leader in receptions with 18 catches for 204 yards and a touchdown... Had his biggest day against Hampton when he had six catches for 59 yards to set up a score in the Bulldogs' 13-6 MEAC victory... Grabbed four catches in a 45-21 loss to B-Cookman and had his lone touchdown reception against Norfolk State - a one-yarder... **2005:** Saw time in seven games last season in his first season of play... caught two passes for 30 yards and a touchdown... also added four special teams tackles last season. **High School:** Earned letters in football at Darlington High School in Darlington, South Carolina... earned All-District honors as well. **Personal:** An Electrical Engineering major... born on August 24, 1986... the son of Mary and Allen Bacote.

Dubose's Career Statistics

Season	GP	Rec.	Yds.	TDs	Avg/C	Avg/G
2005	7	2	30	1	15.0	4.3
2006	11	18	204	1	10.6	16.4
Tot	18	20	234	2	12.8	13.0



#17 Travance Jackson
Defensive Back
5-10, 175 R-Sophomore
Belton, SC (Belton-Honea Path High)

Emerging from spring drills number two on depth chart at the right cornerback position and is expected to compete for starting duties at the position in the fall... Will also play a major role in all phases of special teams... **2006:** Was an impact player on all special teams in all eleven (11) games... Returned a blocked punt for a touchdown in the team's 28-21 win at Florida A&M... Also saw limited action in the Bulldog secondary... Had 20 tackles, 11 unassisted and one for a loss... **2005:** Was redshirted... **High School:** Earned three letters in football, two in basketball, and three in track & field at Belton-Honea Path High School... intercepted a pass and returned it 82 yards for a touchdown in the championship game... was an All-Region safety twice. **Personal:** A Computer Engineering major... born on December 22, 1986... the son of Sonya Jackson and Reginald Brown.

Jackson's Season Statistics

Season	GP	Solo	Tot TFL/Yds.	Sacks/Yds.	Int./Yds	Brup	FR	FF
2006	11	11	20 1/4	-	-	-	-	1

KICK RETURN STATS

KICK RETURNS	No.	Yds	Avg	TD	Long
DUBOSE, Dustin	14	404	28.9	0	65
JACKSON, T.	5	135	27.0	0	45
WOODS, Jonathan	2	10	5.0	0	10
FORD, William	2	54	27.0	0	38
YOUNG, Ricky	1	30	30.0	0	30
QUATTLEBAUM, D.	1	6	6.0	0	6
ADAMS, Phillip	1	10	10.0	0	10
MORRIS, Phillip	1	25	25.0	0	25
Total.....	27	674	25.0	0	65
Opponents.....	26	618	23.8	1	98



KICK RETURN SIDELINE RIGHT vs. 5-5 MIDDLE

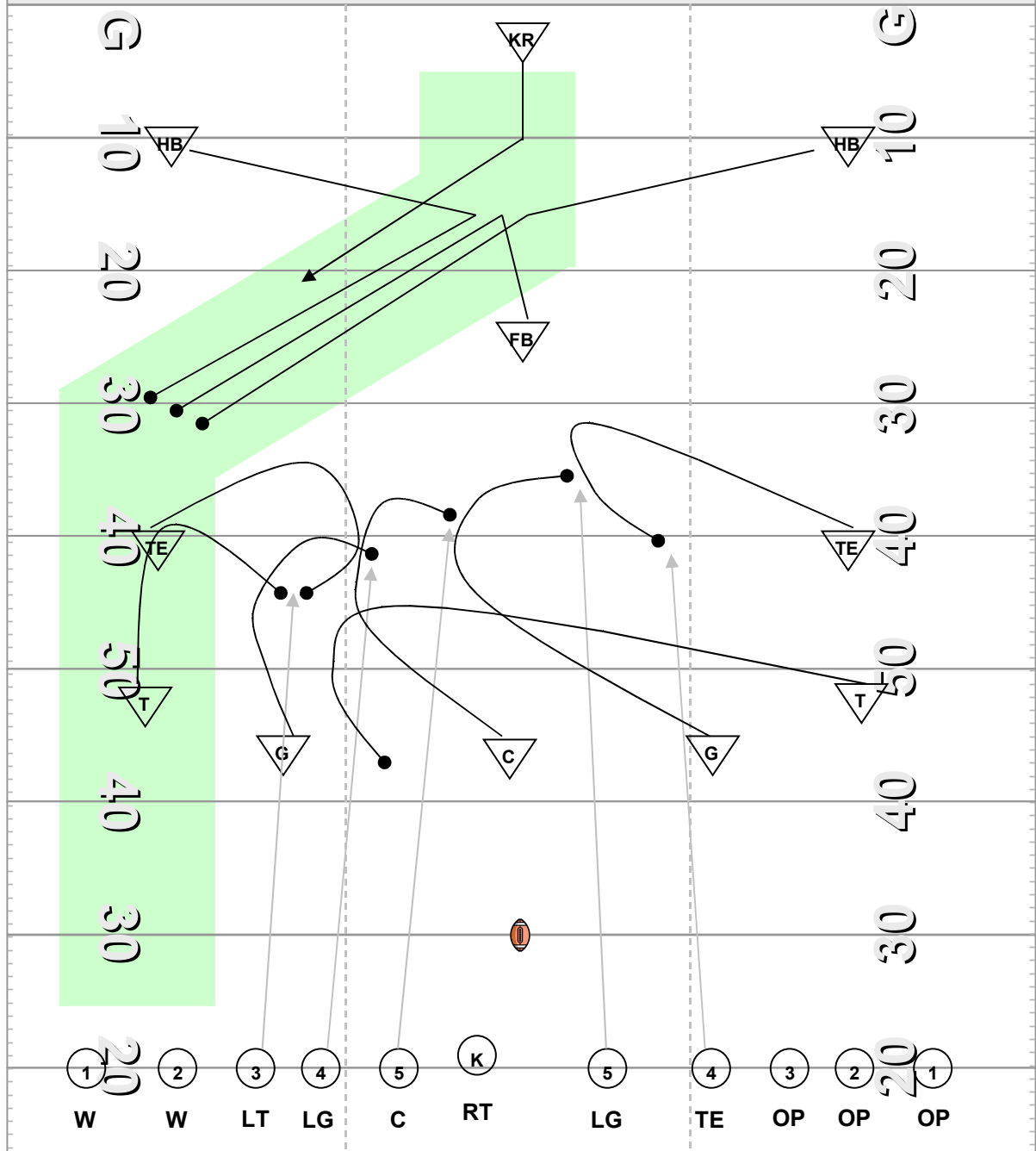

5-2-1-2-1 Look
T: # 47Y
G: Outside Hash 45Y
C: Middle 43Y
TE: # 40Y
FB: Middle 25Y
HB: # 10Y
KR: Middle 5Y-10Y

LT/TE: Double Team L3
LG: Outside-In L4
C: Outside-In L5
RG: Inside-Out R5
RT: Peel Out Kicker
RTE: Inside-Out R4
FB: Lead Wedge to Ball (Middle)
HB's: Wedge Outside
KR: Stay behind Wedge & R4D



KICK RETURN SIDELINE RIGHT vs. 4-6 LEFT

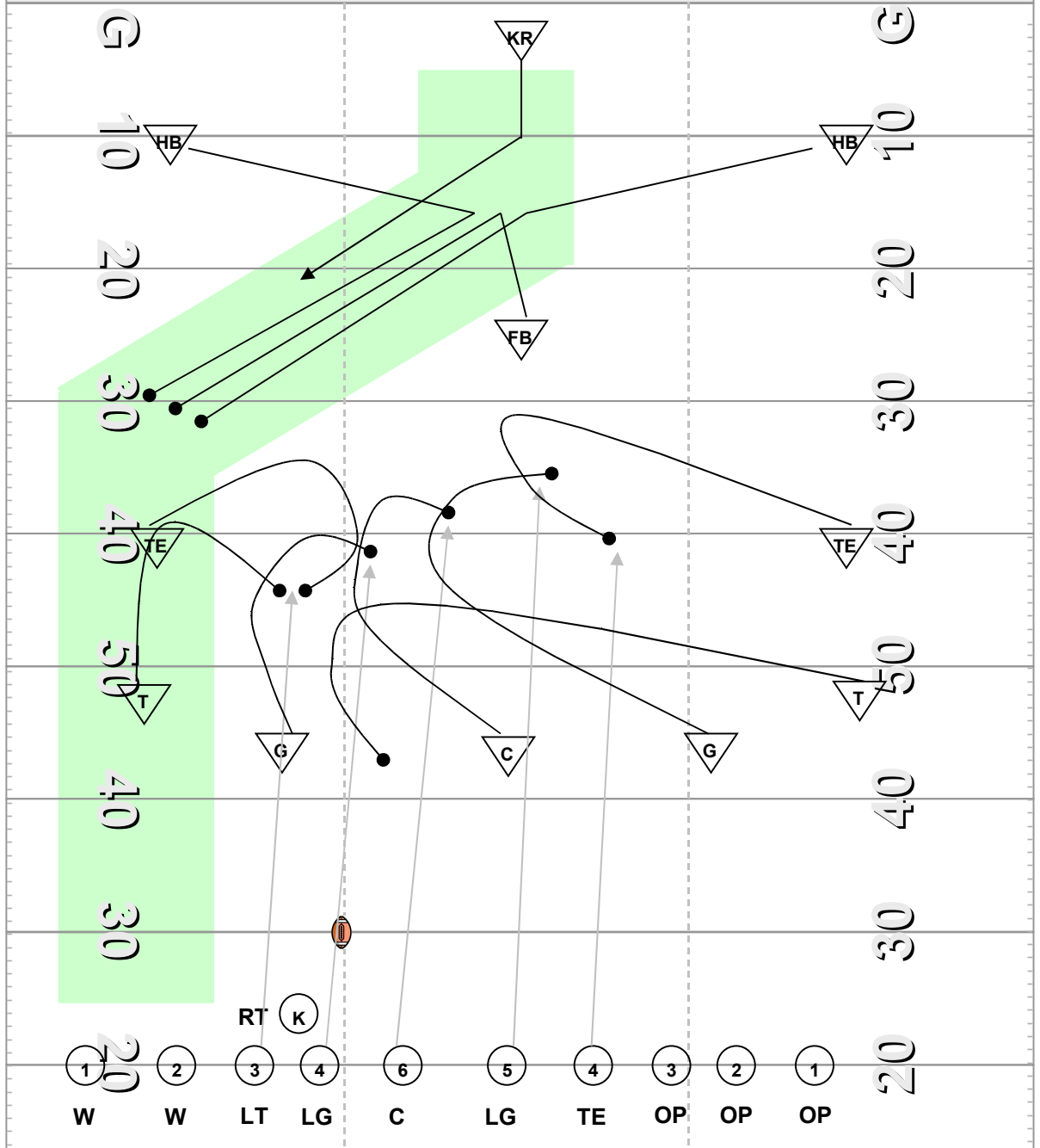

5-2-1-2-1 Look
T: # 47Y
G: Outside Hash 45Y
C: Middle 43Y
TE: # 40Y
FB: Middle 25Y
HB: # 10Y
KR: Middle 5Y-10Y

LT/TE: Double Team L3
LG: Outside-In L4
C: Outside-In R5
RG: Inside-Out R5
RT: Peel Out Kicker
RTE: Inside-Out R4
FB: Lead Wedge to Ball (Middle)
HB's: Wedge Outside
KR: Stay behind Wedge & R4D



KICK RETURN SIDELINE RIGHT vs. 6-4 RIGHT

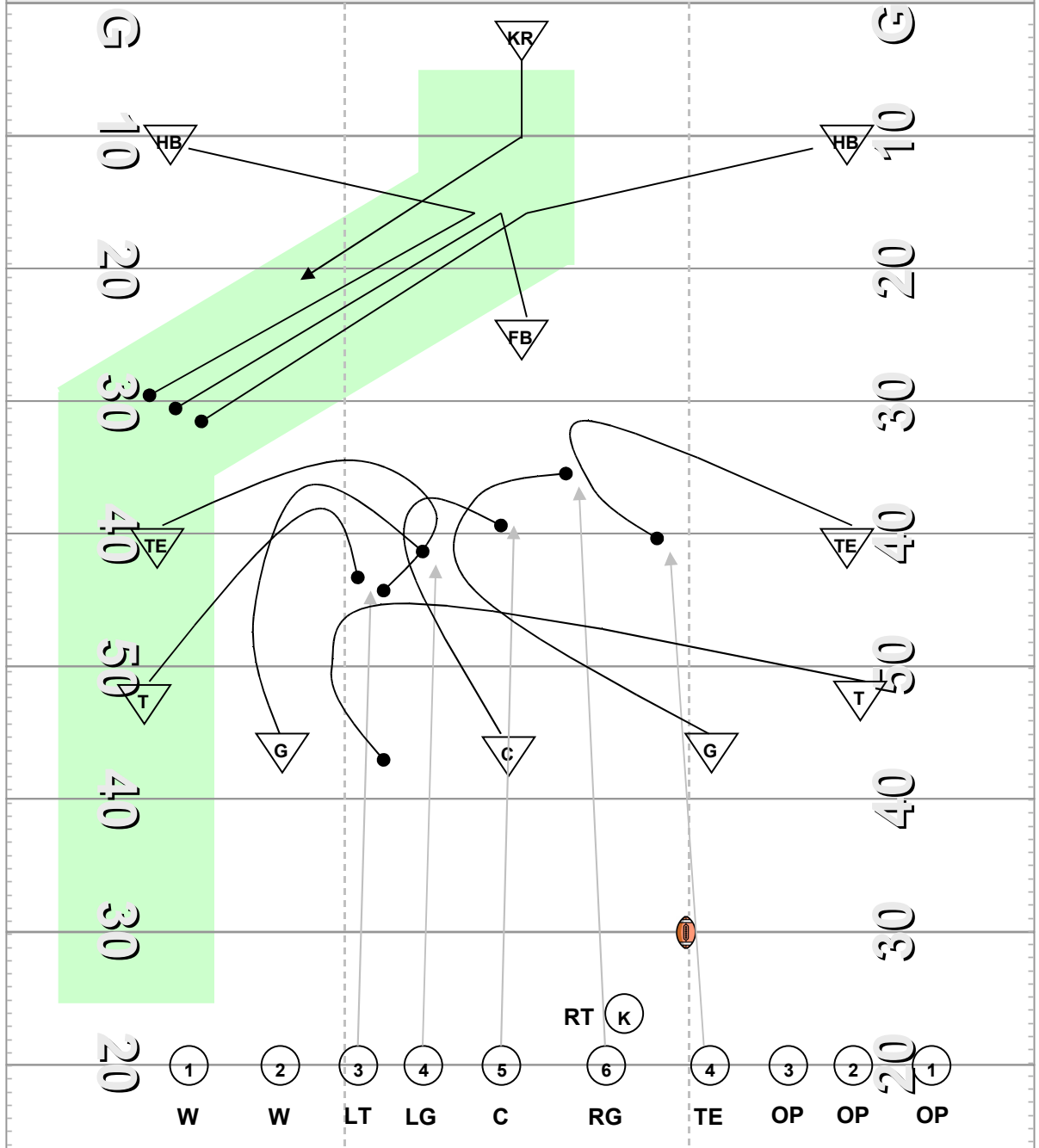

5-2-1-2-1 Look
T: # 47Y
G: Outside Hash 45Y
C: Middle 43Y
TE: # 40Y
FB: Middle 25Y
HB: # 10Y
KR: Middle 5Y-10Y

LT/TE: Double Team L3
LG: Outside-In L4
C: Outside-In L5
RG: Inside-Out L6
RT: Peel Out Kicker
RTE: Inside-Out R4
FB: Lead Wedge to Ball (Middle)
HB's: Wedge Outside
KR: Stay behind Wedge & R4D



KICK RETURN SIDELINE LEFT vs. 5-5 MIDDLE

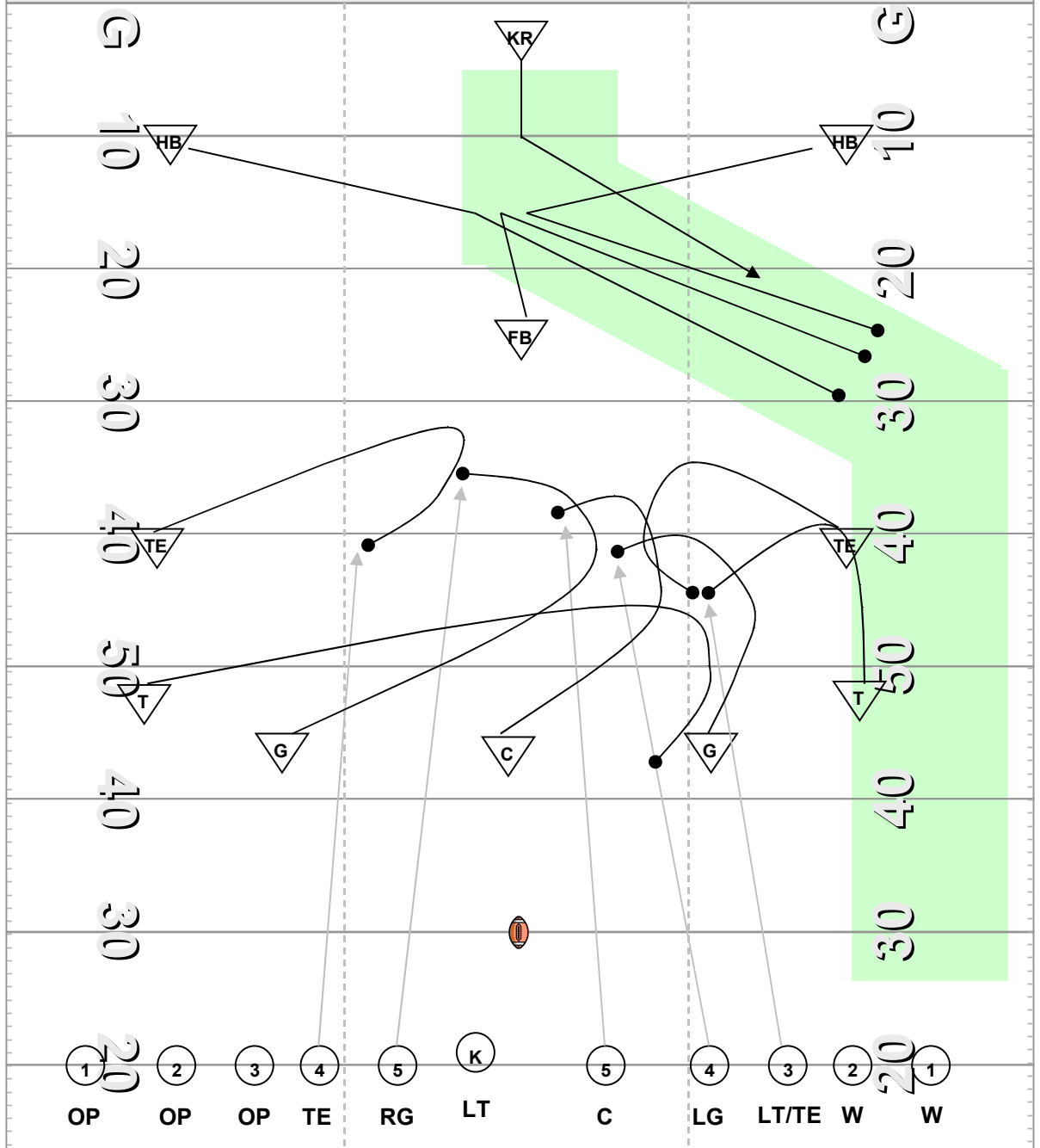

5-2-1-2-1 Look

T: # 47Y

G: Outside Hash 45Y

C: Middle 43Y

TE: # 40Y

FB: Middle 25Y

HB: # 10Y

KR: Middle 5Y-10Y

RT/TE: Double Team L3

RG: Outside-In L4

C: Outside-In L5

LG: Inside-Out R5

LT: Peel Out Kicker

LTE: Inside-Out R4

FB: Lead Wedge to Ball (Middle)

HB's: Wedge Outside

KR: Stay behind Wedge & R4D



KICK RETURN HANDS TEAM

